

# HY2-C

EXTERNAL CAST IRON  
GEAR PUMPS GROUP 2

From 4.5 to 31.7 cc/rev  
Up to 260 bar

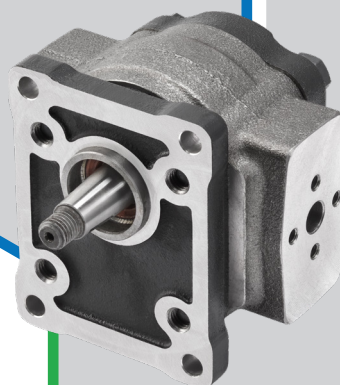

Hydreco is pleased to introduce a brand new range of gear pumps. Based on the experience and knowledge acquired over many years of engineering and manufacturing, the HY2-C series is provided with a cast iron alloy housing, two gear wheels supported by sleeve bearings and cast iron flange and cover.

The HY2-C Series, available as pumps and motors, offers high efficiency, low noise level and can be applied in standard and heavy duty application, thanks to the high reliability and the accuracy of design and production. The pumps can be supplied as single, or as multiple units with a huge variety of options on flanges, shafts and ports, providing the right setup on each application. Feel free to contact your Hydreco representative to find out more and to get the proper support in your selection.

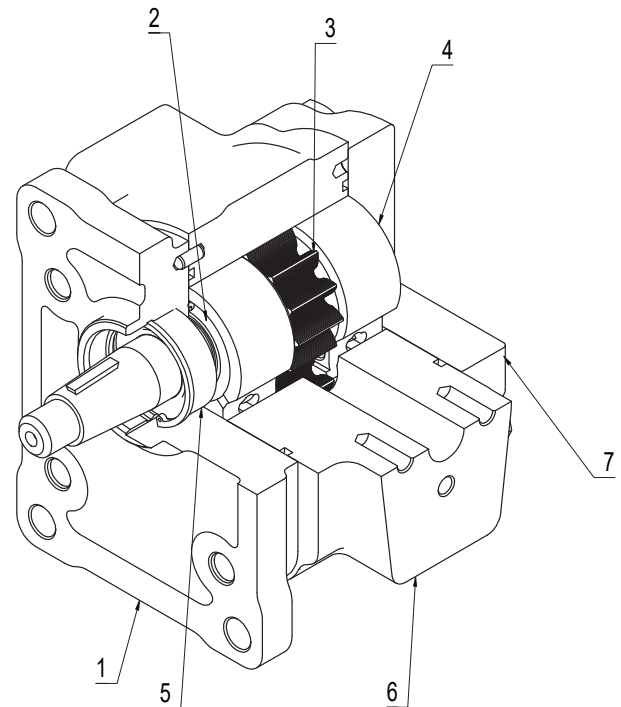

- 1 - Cast Iron Flange
- 2 - Gaskets
- 3 - Gears
- 4 - Bushings
- 5 - Shaft Seal
- 6 - Cast Iron Body
- 7 - Cast Iron Cover

### Displacements

From 4.5 cm<sup>3</sup>/rev to 31.7 cm<sup>3</sup>/rev  
From 0.27 in<sup>3</sup>/rev to 1.93 in<sup>3</sup>/rev

### Pressures

Max continuous 260 bar (3770 psi)  
Max intermittent 290 bar (4200 psi)  
Max peak 310 bar (4500 psi)

### Max Speed

4000 rpm

**HYDRECO**  
Made in Italy

P/N	H2300P002C	
P	C08+04+04-E20TC	
S/N	C210191 1544	

➔

- H2300P002C = Pump / Motor part number
- P or M = Pump or Motor
- P C08+04+04-E20TC = Abbreviate model code - Eg. Triple pump - Clockwise - 8.2cc+4.5cc+4.5cc  
European flange - Tapered shaft 1:8
- C210191 1544 = Serial number - Eg. C(month) - 21 (year) - 0191 (Production order) - 1544(Id. number)
- Arrow = Direction of rotation
- QR Code = Complete model code

**ORDERING CODE IDENTIFICATION FOR SINGLE PUMPS**

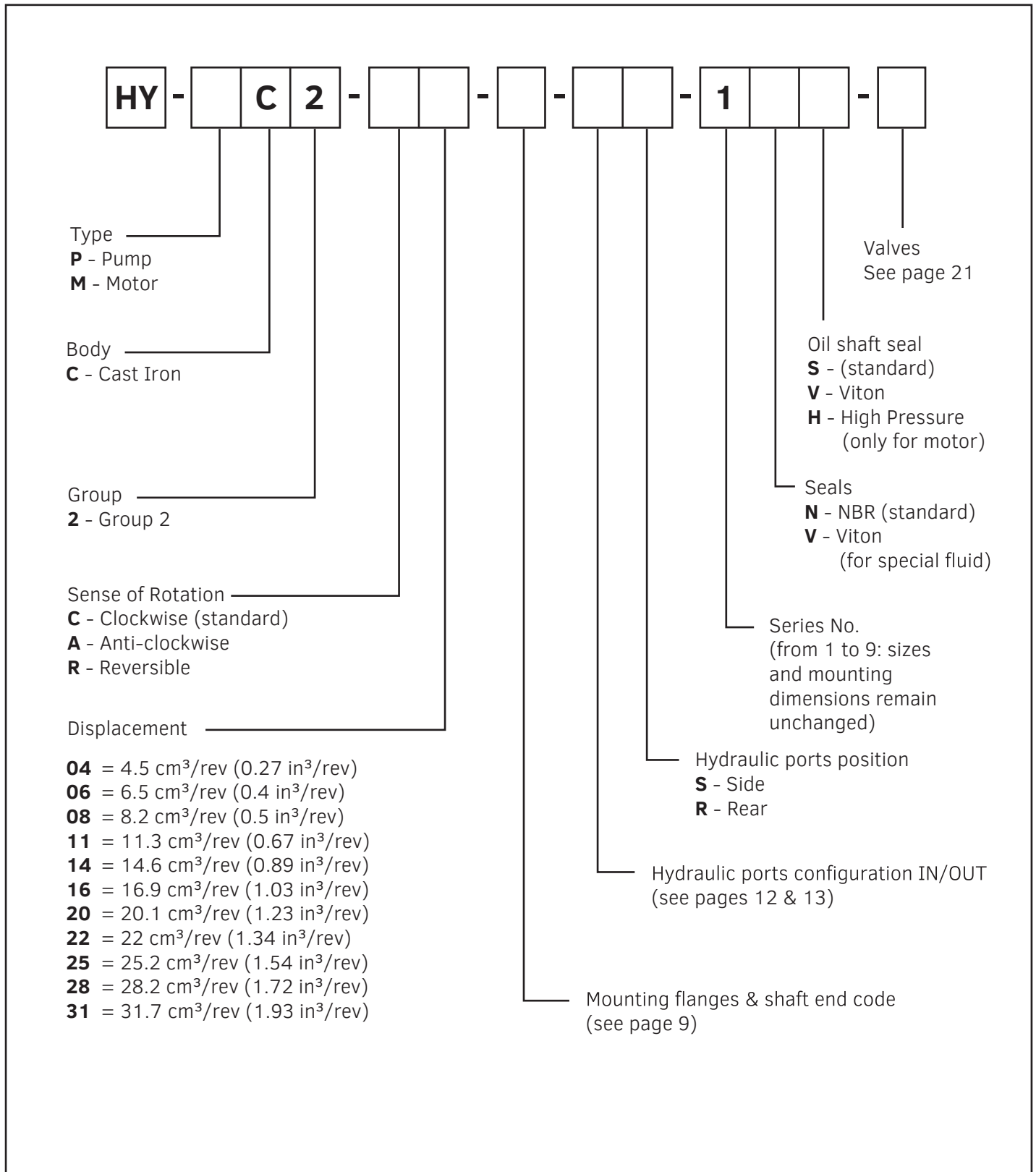

**Example**

HY-PC2-C08-E20T2-FE2/2S-1NS

**ORDERING CODE IDENTIFICATION FOR MULTIPLE PUMPS**

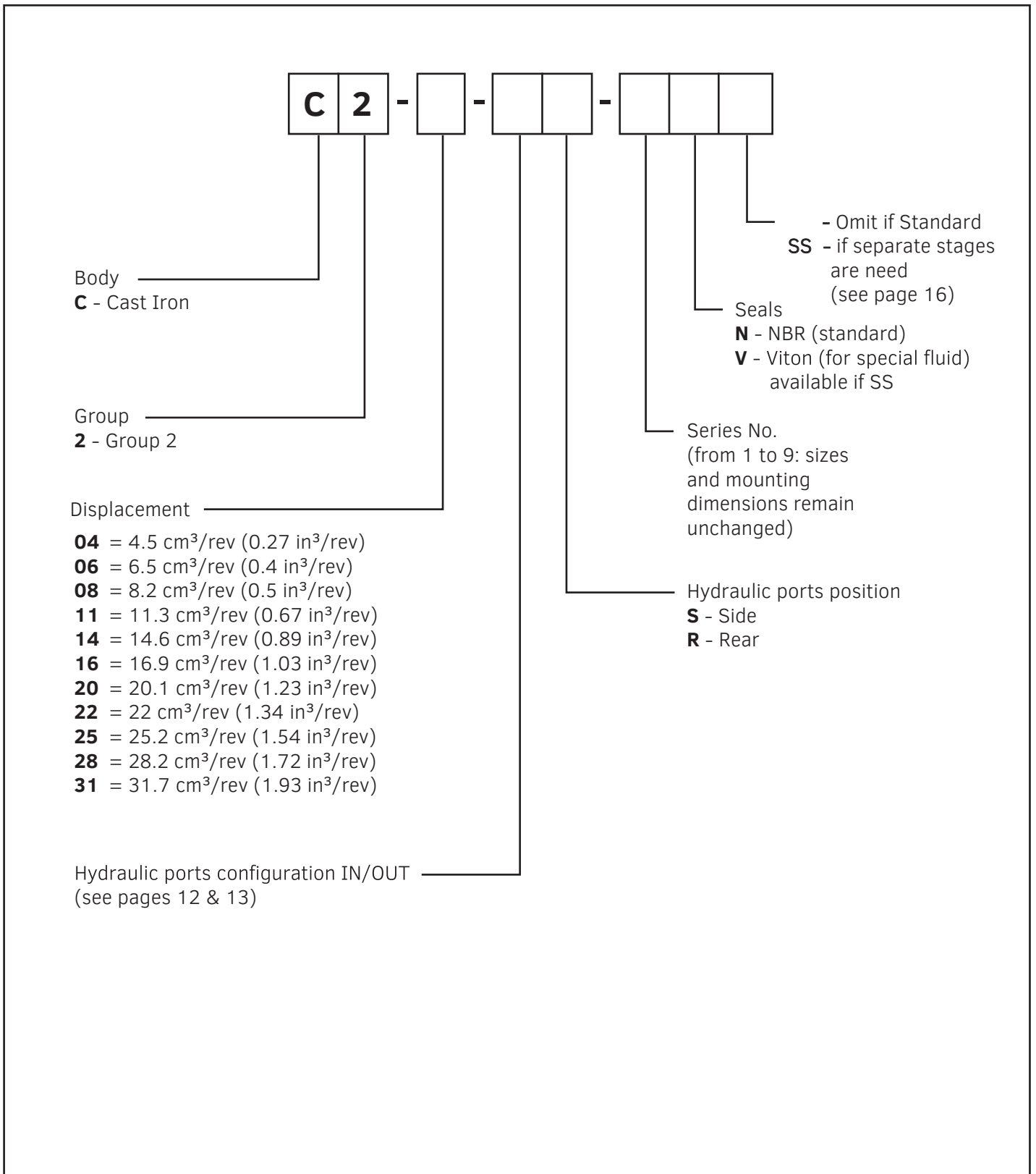

**Example**

HY-PC2-C08-E20T2-FE2/2S-1NS+C2-06-FE2/2S-1N



GROUP	SIZE	DISPLACEMENT cm <sup>3</sup> /rev (in <sup>3</sup> /rev)	MAX PRESSURE bar (psi)			SPEED rpm	
			P1	P2	P3	min	max
HY2	04	4.5 (0.27)	260 (3770)	290 (4200)	310 (4500)	600	4000
	06	6.5 (0.4)	260 (3770)	290 (4200)	310 (4500)	600	4000
	08	8.2 (0.5)	260 (3770)	290 (4200)	310 (4500)	600	4000
	11	11.3 (0.67)	260 (3770)	290 (4200)	310 (4500)	600	4000
	14	14.6 (0.89)	260 (3770)	290 (4200)	310 (4500)	500	3500
	16	16.9 (1.03)	260 (3770)	290 (4200)	310 (4500)	500	3200
	20	20.1 (1.23)	210 (3040)	240 (3480)	260 (3770)	500	3000
	22	22 (1.34)	200 (2900)	230 (3330)	250 (3620)	500	2700
	25	25.2 (1.54)	180 (2610)	210 (3040)	230 (3330)	500	2500
	28	28 (1.72)	160 (2320)	190 (2750)	210 (3040)	500	2200
	31	31.7 (1.93)	150 (2170)	180 (2610)	200 (2900)	500	2000

The data in the table refer to unidirectional pumps and motors.  
The maximum pressures of reversible pumps and motors are 15% lower than unidirectional ones.

For different working conditions please contact Hydreco technical support.

**GENERAL CHARACTERISTICS**

**ROTATION DIRECTION**

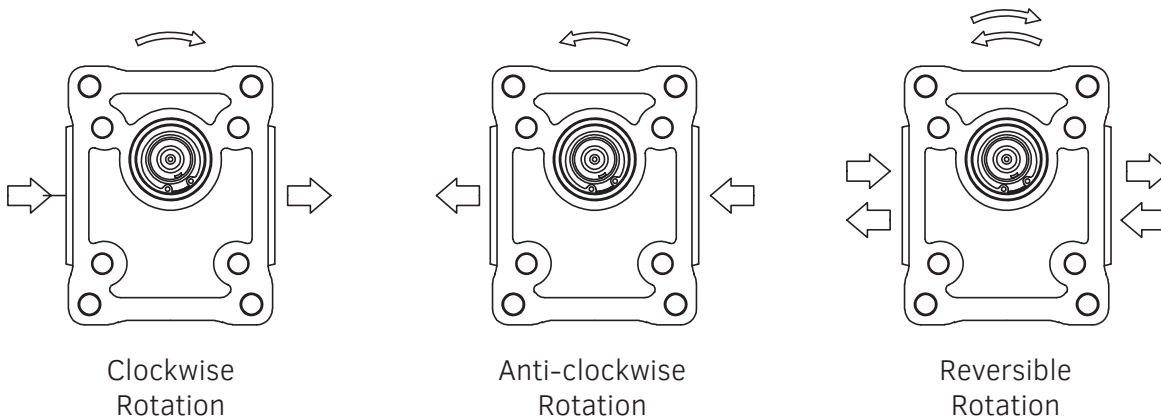

**DEFINITION OF PRESSURES**

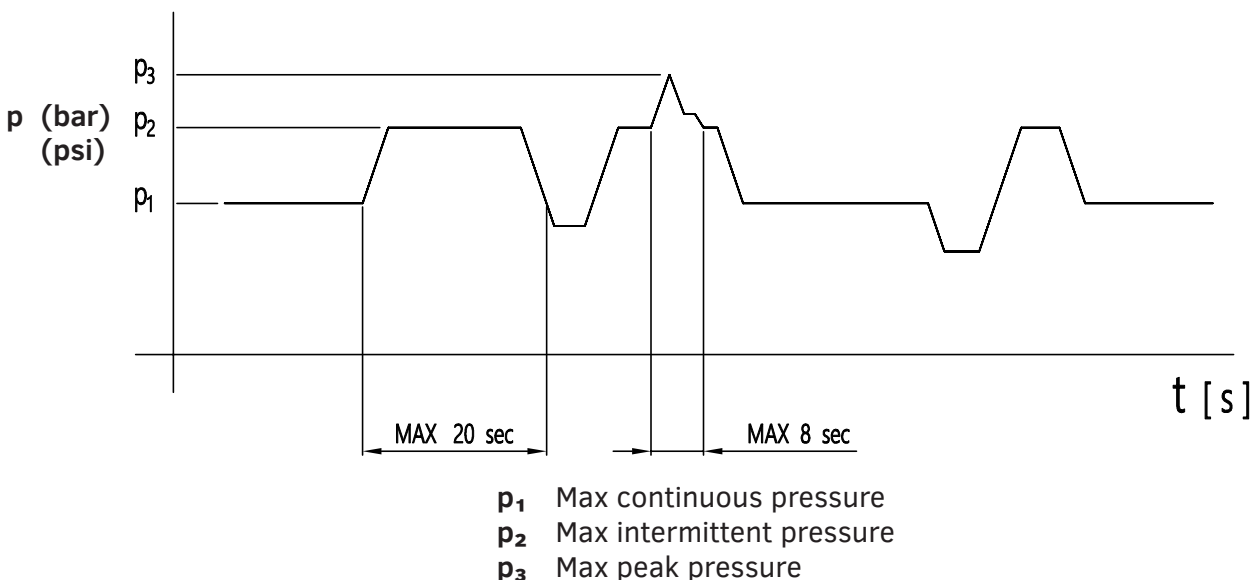

**GENERAL CHARACTERISTICS**

It is essential that pumps are installed so that they can always fill with fluid. 'HY' Series pumps inlet porting is designed to facilitate full volume fill but the following machine design recommendations should be followed.

Direction of rotation (Viewed from shaft end)	Clockwise (C) – Anticlockwise (A) – Reversible (R)
Range inlet pressure – pump	0.7 ÷ 3 bar (10 ÷ 43 psi)
Max back pressure on the unidirectional motors and reversible with internal drainage	P <sub>1</sub> (continue) max 5 bar (72 psi) P <sub>2</sub> (for 20 sec) max 8 bar (115 psi) P <sub>3</sub> (for 5 sec) max 15 bar (215 psi)
Reversible Motor Max pressure in drain	5 bar
Temperature fluid (MIN, MAX, PEAK) °C	-25, 80, 100      NBR -25, 110, 125      VITON
Range of viscosity	From 10 to 100 mm <sup>2</sup> /s (cSt) IDEAL Up to 750 mm <sup>2</sup> /s (cSt) RECOMMENDED Up to 1000 mm <sup>2</sup> /s (cSt) START
Fluid type	Mineral oil

**RECOMMENDED FILTRATION**

Working pressure bar (psi)	$\Delta p < 140$ (2030)	$140$ (2030) < $\Delta p < 210$ (3040)	$\Delta p > 210$ (3040)
Class contamination NAS 1638	10	9	8
Class contamination ISO 4406:1999	21/19/16	20/18/15	19/17/14

- Q = flow rate (L/min)
- V = displacement (cm<sup>3</sup>/rev)
- n = speed (min<sup>-1</sup>)
- M = torque (Nm)
- P = power (kW)
- $\Delta p$  = pressure (bar)

	<b>PUMPS</b>	<b>MOTORS</b>
<b>PERFORMANCE</b>		
$\eta_v$ = volumetric efficiency	≈ 0.96	≈ 0.95
$\eta_{hm}$ = hydro-mechanical efficiency	≈ 0.88	≈ 0.85
$\eta_t$ = total efficiency	≈ 0.84	≈ 0.81

**DETERMINATION OF A PUMP**

$$Q_{\text{theor}} = \frac{V \times n}{1000} \text{ (l/min)} \quad Q_{\text{real}} = Q_{\text{theor}} \times \eta_v$$

$$M_{\text{real}} = \frac{M_{\text{theor}}}{\eta_{\text{hm}}} \text{ (Nm)} \quad M_{\text{theor}} = \frac{\Delta p \times V}{62.8} \text{ (Nm)}$$

$$P_{\text{OUT}} = \frac{\Delta p \times Q}{600} \text{ (kW)} \quad P_{\text{IN}} = \frac{P_{\text{OUT}}}{\eta_t}$$

**DETERMINATION OF A MOTOR**

$$Q_{\text{theor}} = \frac{V \times n}{1000} \text{ (l/min)} \quad Q_{\text{real}} = \frac{Q_{\text{theor}}}{\eta_v}$$

$$M_{\text{theor}} = \frac{\Delta p \times V}{62.8} \text{ (Nm)} \quad M_{\text{real}} = M_{\text{theor}} \times \eta_{\text{hm}}$$

$$P_{\text{OUT}} = \frac{\Delta p \times Q}{600} \text{ (kW)} \quad P_{\text{IN}} = P_{\text{OUT}} \times \eta_t$$

**PUMP SELECTION**

Curves at 40°C - fluid viscosity 46 mm<sup>2</sup>/sec

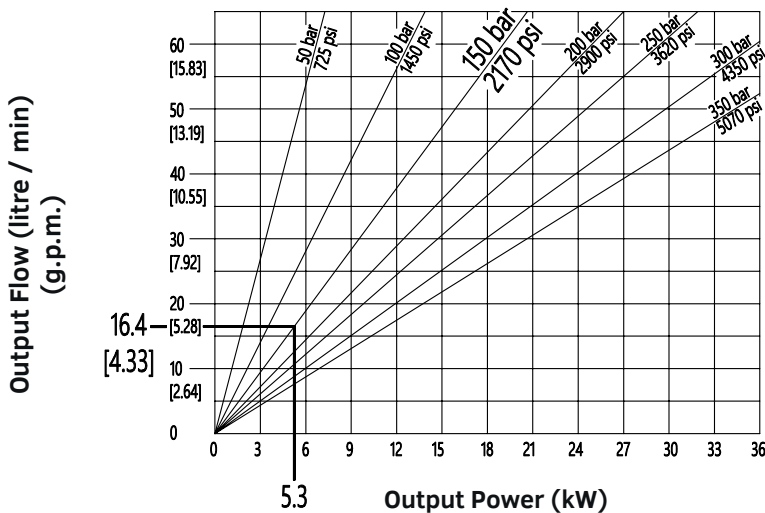
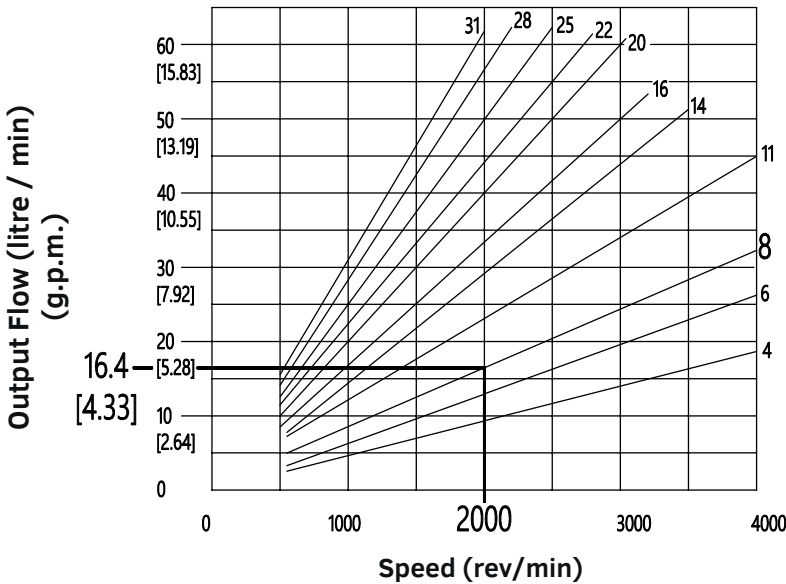

**Example**

Working conditions:  
 Pump 8.2cc  
 Speed 2000 r.p.m.  
 Pressure: 150 bar [2170 psi]  
 Motor: 5.3 kW

OUTPUT FLOWS are theoretical. Generally volumetric efficiencies are in excess of 95%. Please contact your Hydreco representative for specific working conditions.

INPUT POWERS are theoretical taking into account average efficiencies.

**NOTE:**

Diagrams provide approximate selection data

**MOTOR SELECTION**

Curves at 40°C – fluid viscosity 46 mm<sup>2</sup>/sec – 2000r.p.m.

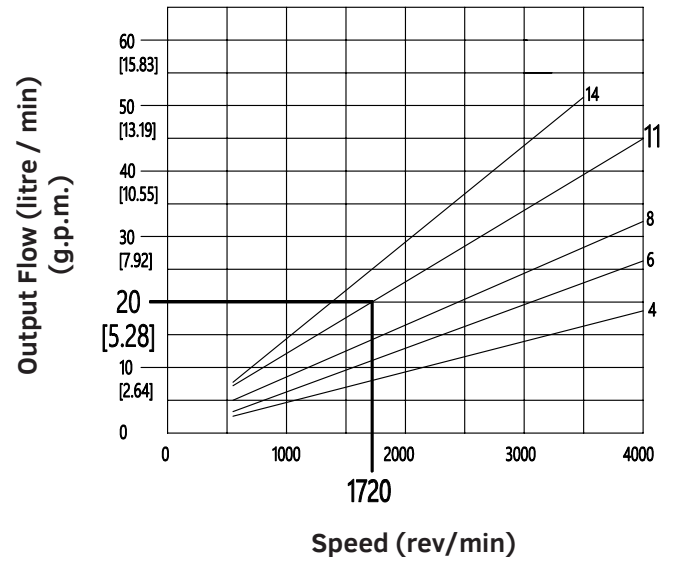
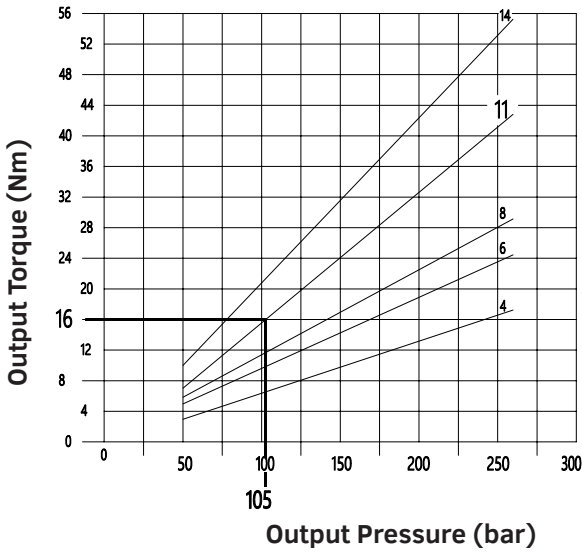

**NOTE:**

Diagrams provide approximate selection data

**Example**

Working conditions:  
Torque needed: 16 Nm  
Available flow 20 litre/min  
Necessary motor: 8 (8.2cc)  
Pressure working: 105 bar  
Speed: 1720 rev/min

**MOTOR SELECTION**

Curves at 40°C – fluid viscosity 46 mm<sup>2</sup>/sec – 1500r.p.m.

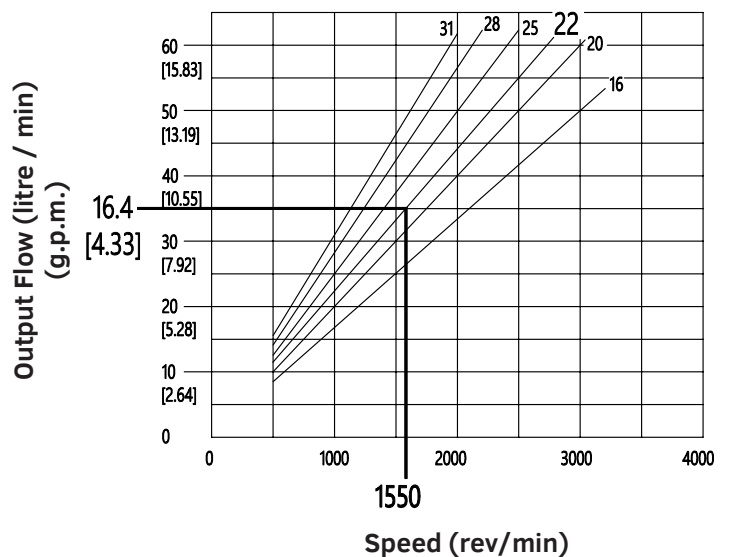
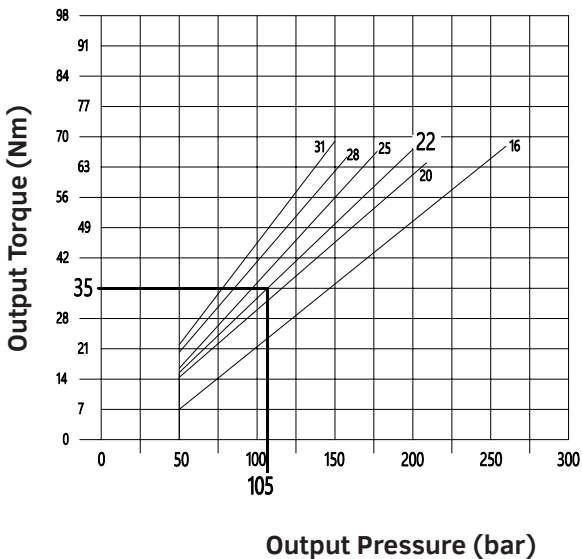

**NOTE:**

Diagrams provide approximate selection data

**Example**

Working conditions:  
Torque needed: 35 Nm  
Available flow 35 litre/min  
Necessary motor: 22 (22cc)  
Pressure working: 105 bar  
Speed: 1550 rev/min

EUROPEAN standard CODE	FLANGE	SHAFT
E20T2	E20 = European flange pilot Ø36.5	T2 = Tapered shaft 1:8 M12

GERMAN standard CODES	FLANGE	SHAFT
G20T6	G20 = German flange pilot Ø80	T6 = Tapered shaft 1:5 M12
G20T9	G20 = German flange pilot Ø80	T9 = Splined shaft 9T - DIN 5482
Z23T6	Z23 = German flange 2 bolts fixing holes on NE-SW	T6 = Tapered shaft 1:5 M12
Z24T6	Z24 = German flange 2 bolts fixing holes on NW-SE	T6 = Tapered shaft 1:5 M12
Z25P2	Z25 = German flange 2 bolts o.ring on spigot fixing holes on NE-SW	P2 = Tang shaft
Z26P2	Z26 = German flange 2 bolts o.ring on spigot fixing holes on NW-SE	P2 = Tang shaft

AMERICAN standard CODES	FLANGE	SHAFT
A09T	A = SAE A flange Ø82	09T = Splined shaft 9T 16/32
A11T	A = SAE A flange Ø82	11T = Splined shaft 11T 16/32
A058P	A = SAE A flange Ø82	058P = Parallel shaft Ø15.85

For other configurations than those indicated, please contact Hydreco technical support.

FLANGES OPTIONS

<p>Code <b>E20</b> EUROPEAN</p>	<p>Code <b>G20</b> GERMAN</p>
<p>Code <b>A</b> SAE (A) - 2 BOLTS</p>	Empty space for drawing
Empty space for drawing	Empty space for drawing

**FLANGES OPTIONS**

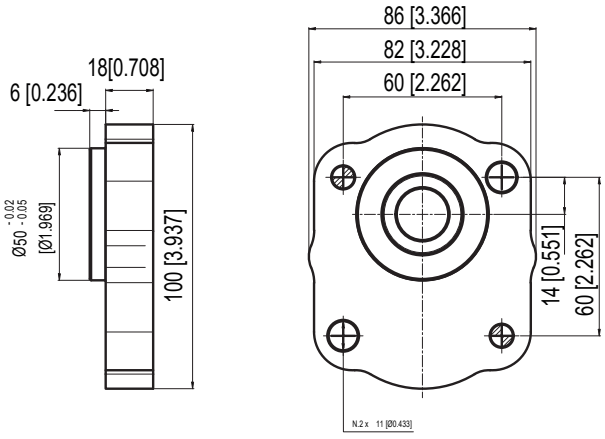
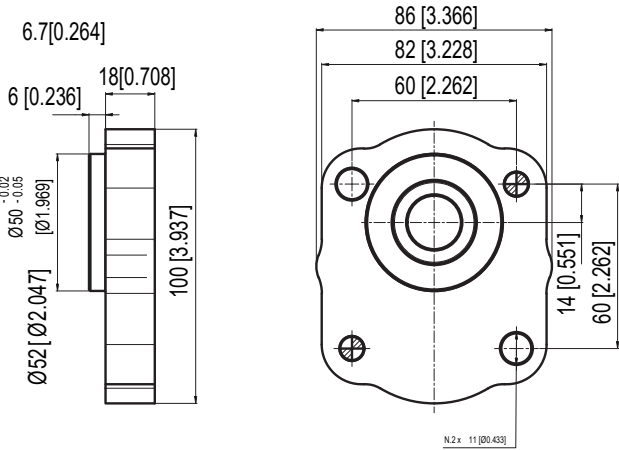
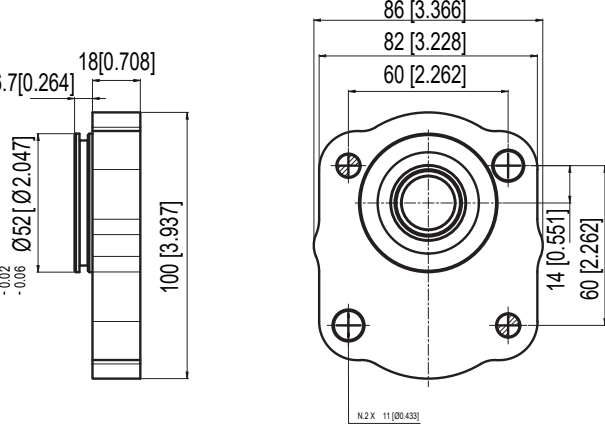
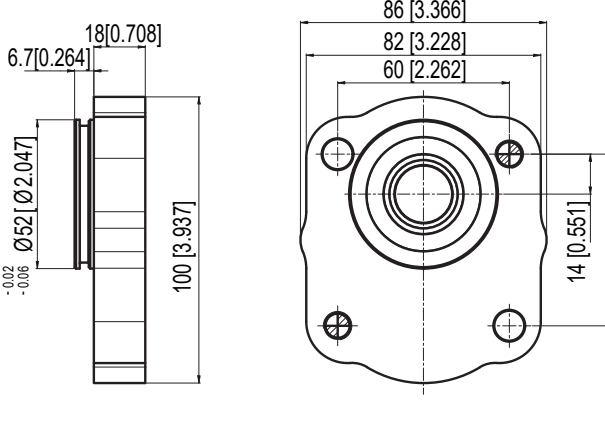
<p>Code <b>Z23</b> GERMAN FLANGE - 2 BOLTS</p> 	<p>Code <b>Z24</b> GERMAN FLANGE - 2 BOLTS</p> 
<p>Code <b>Z25</b> GERMAN FLANGE - 2 BOLTS</p> 	<p>Code <b>Z26</b> GERMAN FLANGE - 2 BOLTS</p> 

**SHAFT OPTIONS**

Code **09T** SAE (A) 5/8" spline

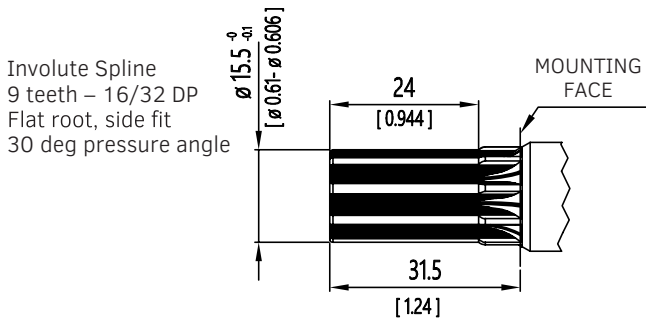

Max Torque = 100 Nm (885 lbf in)

Code **11T** SAE (A) 3/4" spline

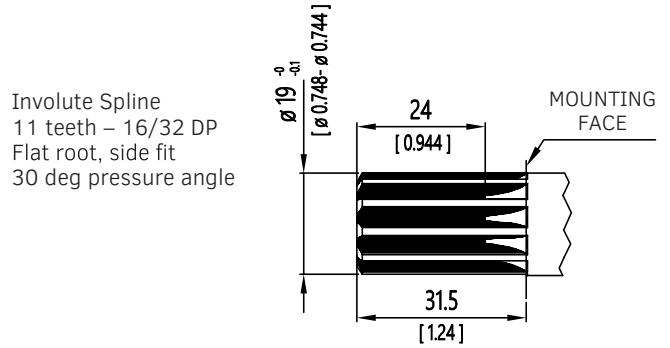

Max Torque = 170 Nm (1505 lbf in)

Code **058P** SAE (A) 5/8" parallel

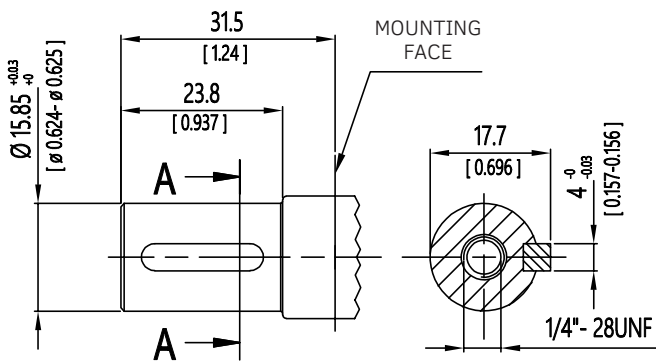

Max Torque = 70 Nm (620 lbf in)

Code **T2** European Tapered 1:8

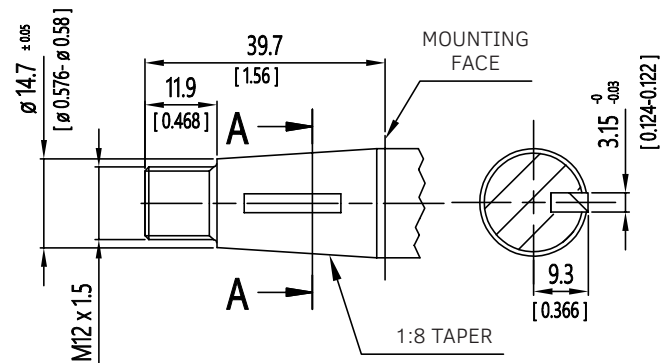

Max Torque = 140 Nm (1240 lbf in)

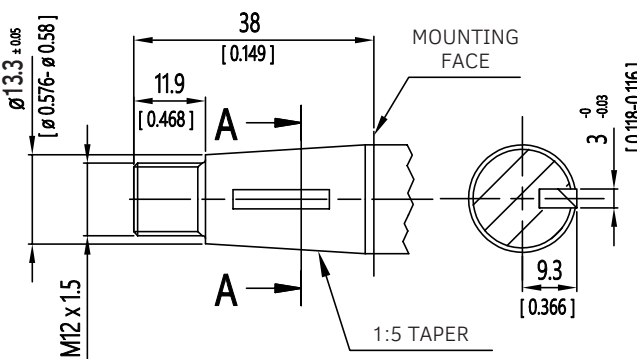
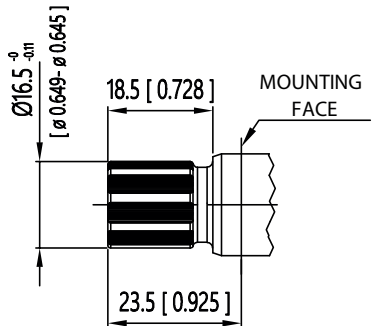
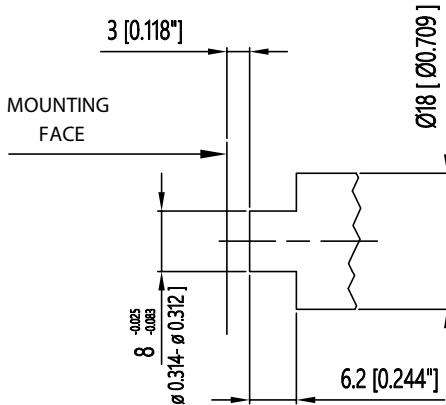

**SHAFT OPTIONS**

<p>Code <b>T6</b> German Tapered 1:5</p>  <p>Max Torque = 140 Nm ( 1240 lbf in )</p>	<p>Code <b>T9</b> 9T - DIN5482</p> <p>Ext. Involute Spine B 17 x 14 x e9 DIN 5482</p>  <p>Max Torque = 110 Nm ( 974 lbf in )</p>
<p>Code <b>P2</b> Tang shaft</p>  <p>Max Torque = 70 Nm ( 620 lbf in )</p>	

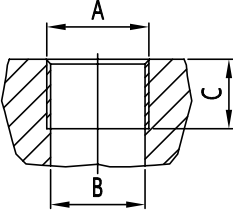
BSPP THREADED PORTS (B) Compliant with ISO 228	Ordering Code	Dimension mm (inches)			Tightening Torque Nm [lbf in]	
		A	B	C	Low Pressure	High Pressure
	2	1/2"	19 (0.748)	14 (0.551)	20 [180]	50 [440]
	3	3/4"	24 (0.944)	18 (0.708)	30 [265]	80 [710]
	4	1"	30 (1.181)	22 (0.866)	50 [440]	120 [1060]

STANDARD PORT CONFIGURATION				
CODE	SUCTION	PRESSURE	POSITION	SIZE
B2/2S	2 = 1/2" BSPP	2 = 1/2" BSPP	S = SIDE	4 to 8
B3/2S	3 = 3/4" BSPP	2 = 1/2" BSPP	S = SIDE	11 to 31
B2/2R	2 = 1/2" BSPP	2 = 1/2" BSPP	R = REAR	4 to 8
B3/2R	3 = 3/4" BSPP	2 = 1/2" BSPP	R = REAR	11 to 31

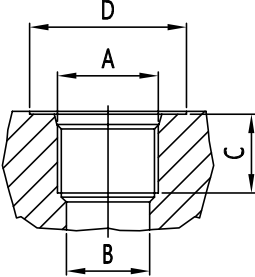
SAE THREADED PORTS (U) Compliant with SAE J514	Ordering Code	Dimensions mm (inches)				Tightening Torque Nm [lbf in]	
		A	B	C	D	Low Pressure	High Pressure
	25	7/8" - 14 UNF	20 (0.787)	17 (0.669)	35 (1.377)	30 [265]	70 [620]
	3	1 1/16" - 12 UNF	24 (0.944)	17 (0.669)	42 (1.653)	40 [355]	120 [1060]

STANDARD PORTS CONFIGURATION				
CODE	SUCTION	PRESSURE	POSITION	SIZE
U25/25S	25 = 7/8" 14 UNF	25 = 7/8" 14 UNF	S = SIDE	4 to 11
U3/25S	3 = 1 1/16" 12 UNF	25 = 7/8" 14 UNF	S = SIDE	14 to 31
U25/25R	25 = 7/8" 14 UNF	25 = 7/8" 14 UNF	R = REAR	4 to 11
U3/25R	3 = 1 1/16" 12 UNF	25 = 7/8" 14 UNF	R = REAR	14 to 31

INLET PORTS = For multiple pumps with single inlet please contact Hydreco technical support

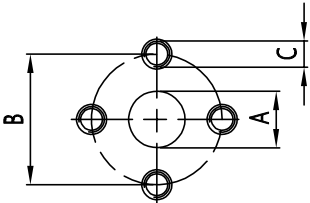
EUROPEAN FLANGED PORTS (FE)	Ordering Code	Dimensions mm (inches)			Tightening Torque Nm [lbf in]	
		A	B	C	Low Pressure	High Pressure
	2	13 (0.511)	30 (1.181)	M6	8 [70]	8 [70]
	3	20 (0.787)	40 (1.574)	M8	15 [130]	15 [130]

STANDARD PORTS CONFIGURATION				
CODE	SUCTION	PRESSURE	POSITION	SIZE
FE2/2S	2 = Ø13 mm	2 = Ø13 mm	SIDE (only)	4 to 8
FE3/2S	3 = Ø20 mm	2 = Ø13 mm	SIDE (only)	11 to 31

**NOTE:** For pump HYC2 type 11 PORTS SUCTION AND PRESSURE CODE FE2/2S

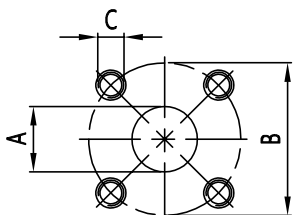
GERMAN FLANGED PORTS (FG)	Ordering Code	Dimensions mm (inches)			Tightening Torque Nm [lbf in]	
		A	B	C	Low Pressure	High Pressure
	25	15 (0.59)	35 (1.377)	M6	8 [70]	8 [70]
	3	20 (0.787)	40 (1.574)	M6	8 [70]	8 [70]

STANDARD PORTS CONFIGURATION				
CODE	SUCTION	PRESSURE	POSITION	SIZE
FG3/25S	3 = Ø20 mm	25 = Ø15 mm	SIDE (only)	ALL

INLET PORTS = For multiple pumps with single inlet please contact Hydreco technical support

PORTS OPTIONS

HY2-C - STANDARD PORTS								
	PUMP/MOTOR UNI-DIRECTIONAL				PUMP/MOTOR REVERSIBLE			
PORTS TYPE	B	FE	FG	U	B	FE	FG	U
Displacement								
04	2/2	2/2	3/25	25/25	2/2	2/2	3/25	25/25
06	2/2	2/2	3/25	25/25	2/2	2/2	3/25	25/25
08	2/2	2/2	3/25	25/25	2/2	2/2	3/25	25/25
11	3/2	3/2	3/25	25/25	3/3	3/3	3/25	25/25
14	3/2	3/2	3/25	3/25	3/3	3/3	3/25	3/25
16	3/2	3/2	3/25	3/25	3/3	3/3	3/25	3/25
20	3/2	3/2	3/25	3/25	3/3	3/3	3/25	3/25
22	3/2	3/2	3/25	3/25	3/3	3/3	3/25	3/25
25	3/2	3/2	3/25	3/25	3/3	3/3	3/25	3/25
28	3/2	3/2	3/25	3/25	3/3	3/3	3/25	3/25
31	3/2	3/2	3/25	3/25	3/3	3/3	3/25	3/25

**SINGLE PUMPS**

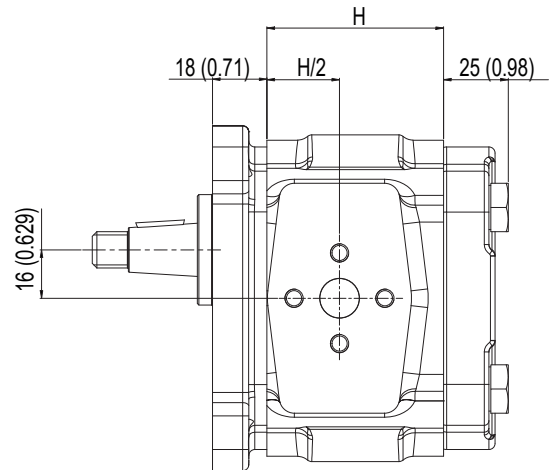
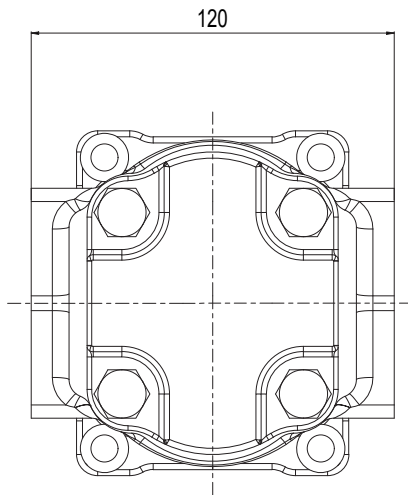

**UNIDIRECTIONAL COVER**

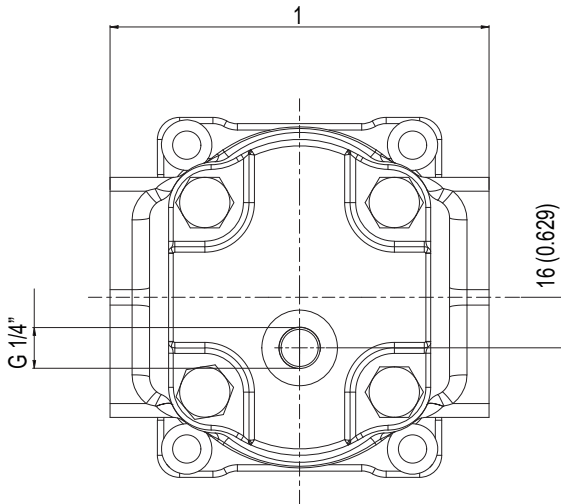

GROUP	PUMP / MOTOR SIZE	H mm (inches)	WEIGHT (Kg)
HY2-C	04	48.6 (1.913)	3.4
	06	51.5 (2.027)	3.4
	08	54.0 (2.125)	3.5
	11	58.4 (2.299)	3.5
	14	63.2 (2.488)	3.6
	16	66.6 (2.622)	3.6
	20	71.3 (2.807)	3.8
	22	82.0 (3.228)	4.2
	25	86.6 (3.409)	4.2
	28	91.0 (3.582)	4.5
31	96.1 (3.783)	4.5	

Indicative weights - European flange and 1:8 tapered shaft

**REVERSIBLE COVER**

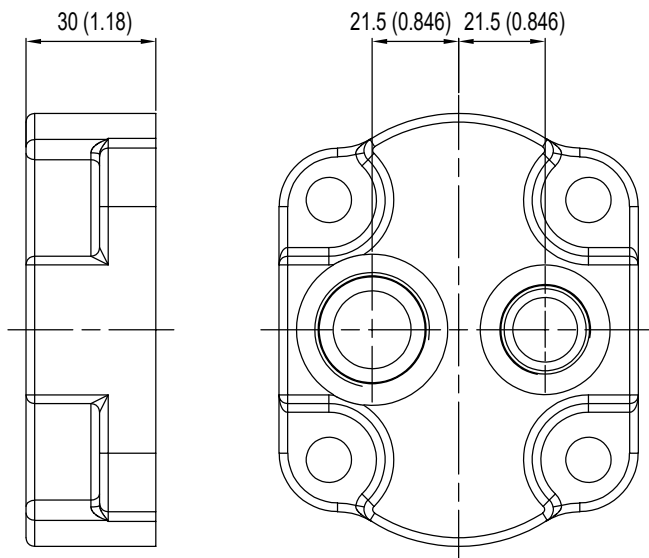

Available rear ports: BSPP and SAE  
(see page 12)

**DIMENSIONS ( side view )**

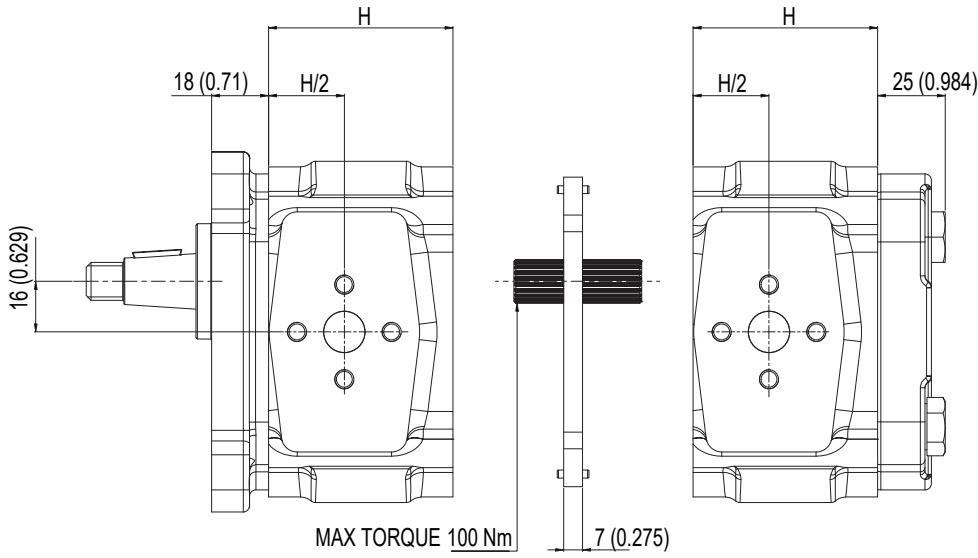
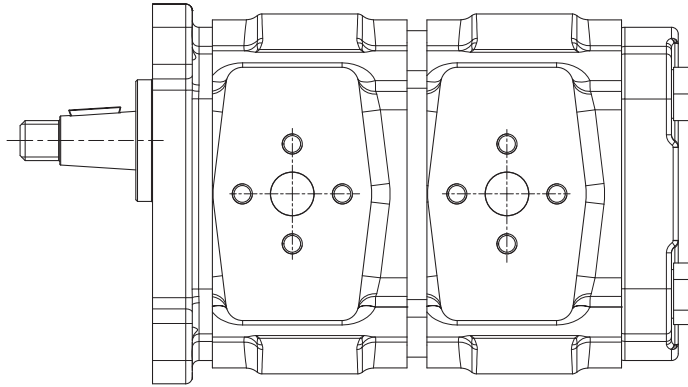

**STANDARD CONFIGURATION**  
tandem pumps

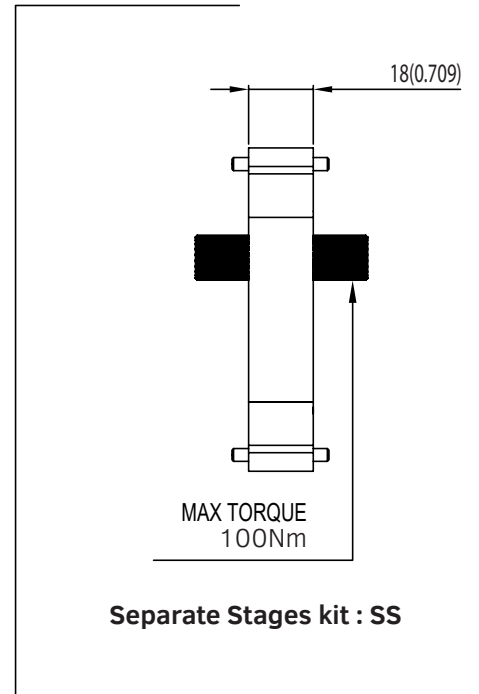

**Separate Stages kit : SS**

GROUP	PUMP SIZE	H mm (inches)	PUMP TYPE	H mm (inches)
<b>HY2-C</b>	04	48.6 (1.913)	20	71.3 (2.807)
	06	51.5 (2.027)	22	82.0 (3.228)
	08	54.0 (2.125)	25	86.6 (3.409)
	11	58.4 (2.299)	28	91.0 (3.582)
	14	63.2 (2.488)	31	96.1 (3.783)
	16	66.6 (2.622)		

**TANDEM PUMPS SCREW LENGTHS**

SIZE cc Gr.2	04	06	08	11	14	16	20	22	25	28	31
04	135	140	140	145	150	155	160	170	175	180	185
06		145	145	150	155	155	160	175	175	180	185
08			145	150	155	160	165	175	180	185	190
11				155	160	165	170	180	185	190	195
14					165	170	175	185	190	195	200
16						170	175	190	190	200	200
20							180	190	200	200	205
22								200	200	210	215
25									210	215	220
28										220	225
31											230

**TANDEM PUMPS HY2+HY2**  
**M10 screws size**  
**10.9 screws class**  
**Screws Tightening Torque = 60 +/- 2 Nm**  
**Length expressed in millimeters**

**EXAMPLES WITH COMMON INLET (top view)**

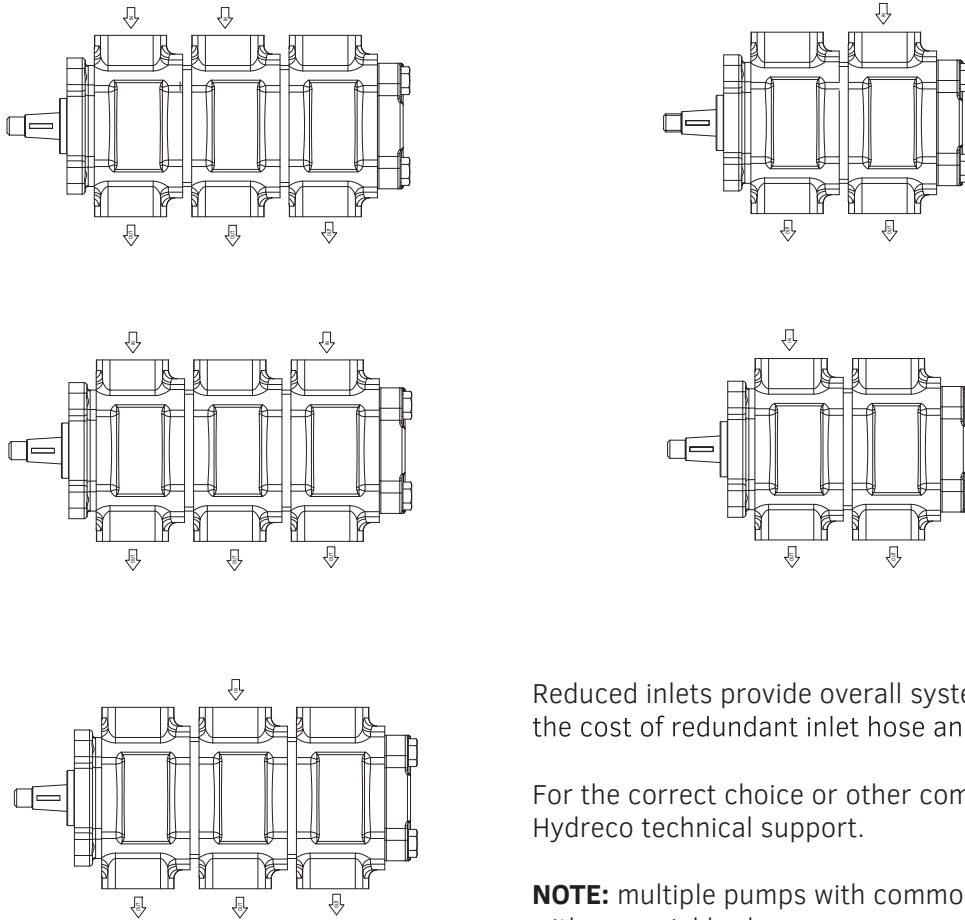

Reduced inlets provide overall systems savings by reducing the cost of redundant inlet hose and fittings.

For the correct choice or other combinations please contact Hydreco technical support.

**NOTE:** multiple pumps with common inlet will be provided with a special body

**DIMENSIONS (side view)**

The HY2-C intermediate pumps include the intermediate flange & coupling to easily assemble tandem or multiple pumps.

GROUP	PUMP SIZE	H mm (inches)	PUMP SIZE	H mm (inches)
HY2-C	04	48.6 (1.913)	20	71.3 (2.807)
	06	51.5 (2.027)	22	82.0 (3.228)
	08	54.0 (2.125)	25	86.6 (3.409)
	11	58.4 (2.299)	28	91.0 (3.582)
	14	63.2 (2.488)	31	96.1 (3.783)
	16	66.6 (2.622)		

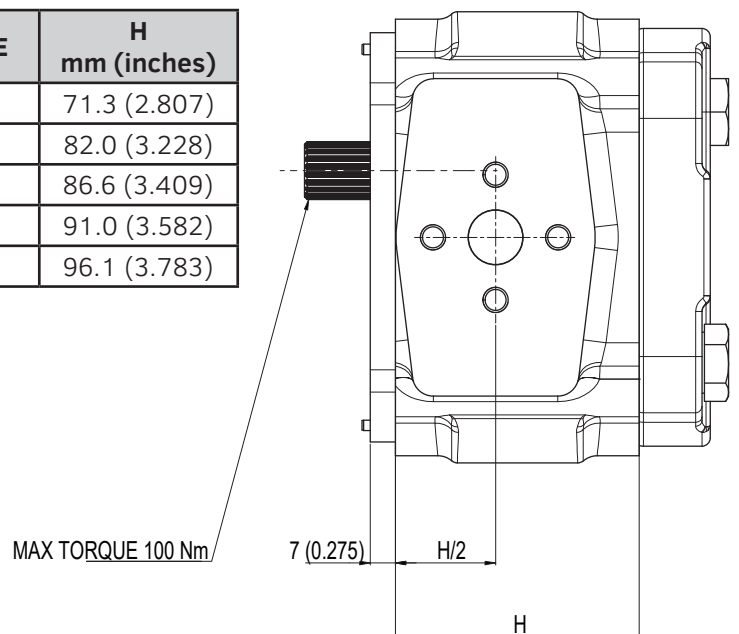



**ORDERING CODE IDENTIFICATION FOR STAND ALONE INTERMEDIATE PUMPS**

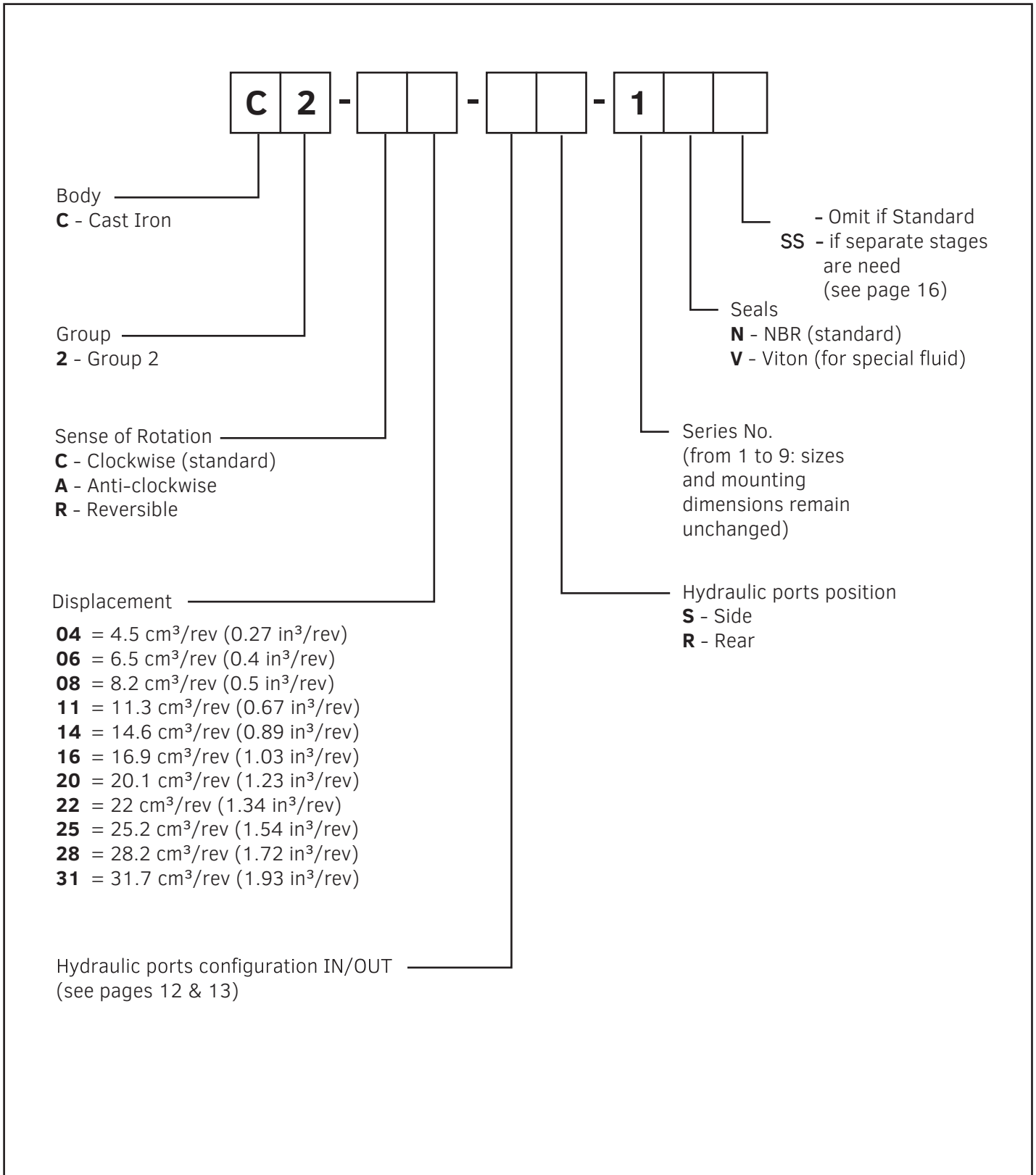

**Example**

C2-C06-FE2/2S-1N

**HOW TO MAKE TANDEM PUMPS USING AN INTERMEDIATE PUMP (side view)**

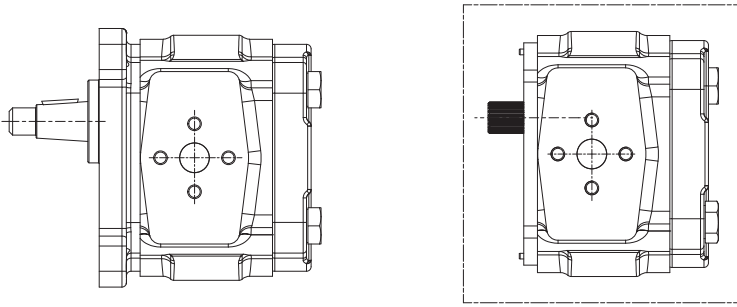

**STANDARD PUMP**

**INTERMEDIATE PUMP**

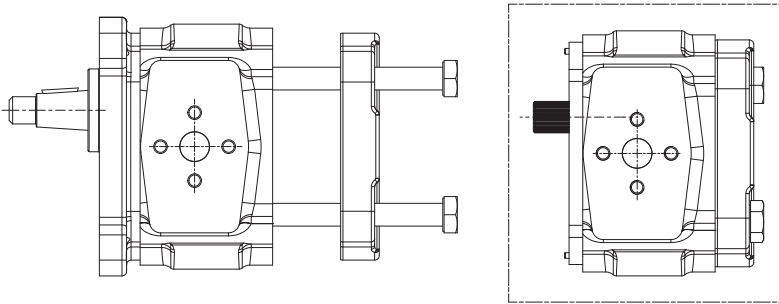

**A.** Loosen, and remove, the clamp screws and remove the cover.

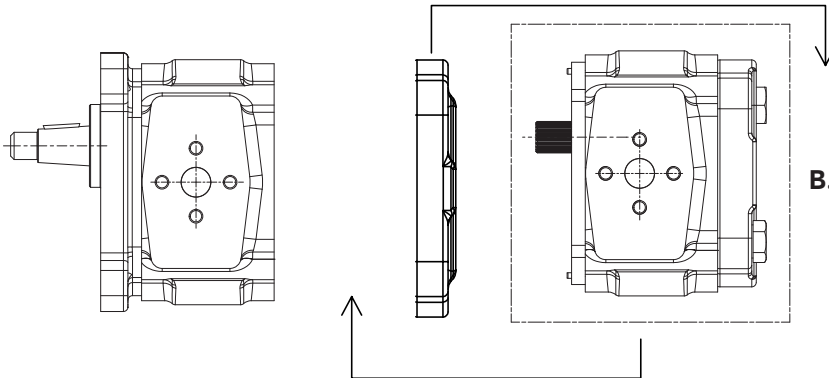

**B.** Connect the intermediate pump

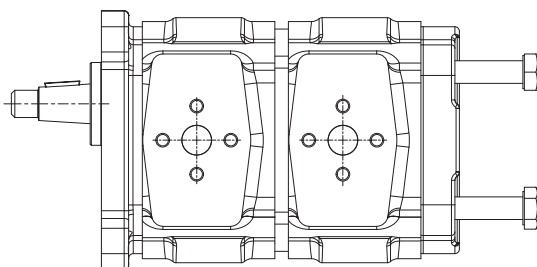

**C.** Assembling the tandem pump.  
Refit the clamp screws.  
SCREWS TIGHTENING TORQUE =  $60 \pm 2$ Nm  
For length of closure screws = see page 15

**DIMENSIONS (side view)**

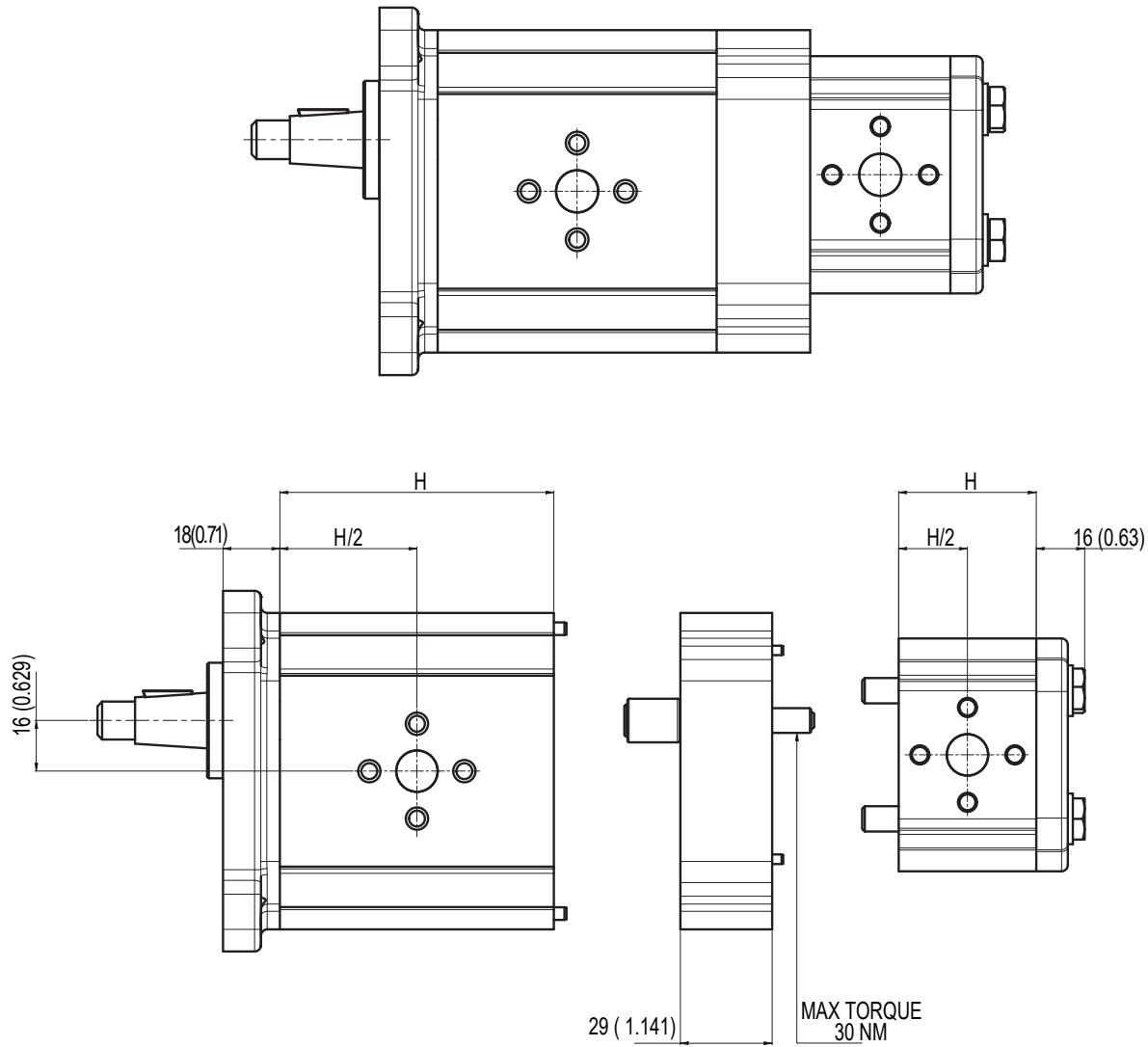

GROUP	PUMP / MOTOR SIZE	H mm (inch)
<b>HY2</b>	04	48.6 (1.913)
	06	51.5 (2.027)
	08	54.0 (2.125)
	11	58.4 (2.299)
	14	63.2 (2.488)
	16	66.6 (2.622)
	20	71.3 (2.807)
	22	82.0 (3.228)
	25	86.6 (3.409)
	28	91.0 (3.582)
	31	96.1 (3.783)

GROUP	SIZE	H mm (inch)
<b>HY1</b>	010	35.7 (1.405)
	015	37.5 (1.476)
	019	39.0 (1.535)
	025	41.3 (1.626)
	031	43.5 (1.712)
	038	46.1 (1.814)
	047	49.5 (1.949)
	053	51.7 (2.035)
	063	55.5 (2.180)
	075	59.2 (2.330)

Code **REV** RELIEF VALVE WITH EXTERNAL DRAIN (ADJUSTABLE SETTING)

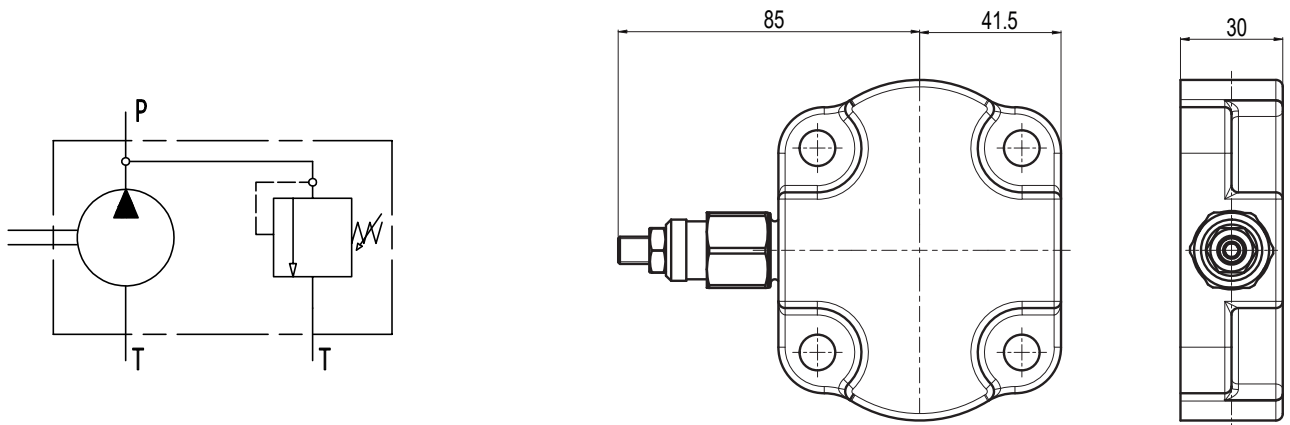

Code **RIV** RELIEF VALVE WITH INTERNAL DRAIN (ADJUSTABLE SETTING)

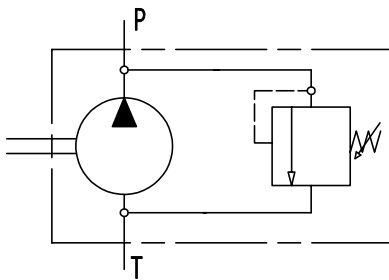

Spring CODE	Pressure setting range bar (psi)
<b>N</b>	10 – 105 (145 – 1522)
<b>B</b>	70 – 210 (1015 – 1885)
<b>G</b>	140 – 260 (2030 – 3770)

Ordering example (add at the end of the pump or motor code) : RIVB(150)

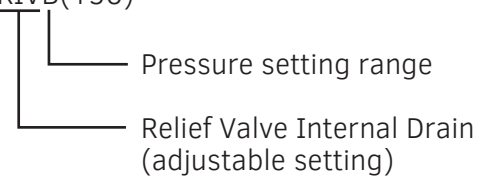

Code **REF** RELIEF VALVE WITH EXTERNAL DRAIN (FIXED SETTING)

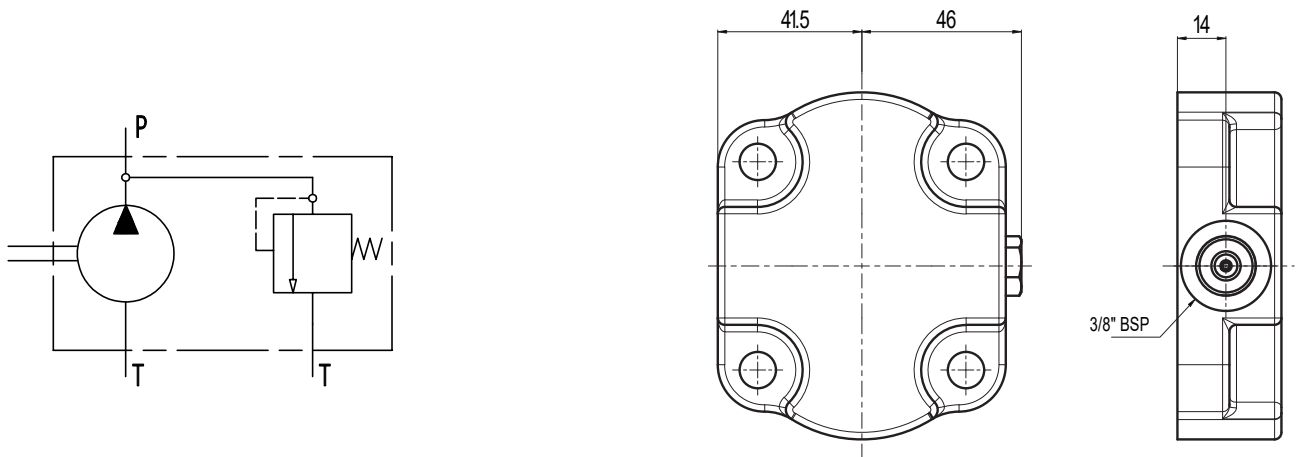

Code **RIF** RELIEF VALVE WITH INTERNAL DRAIN (FIXED SETTING)

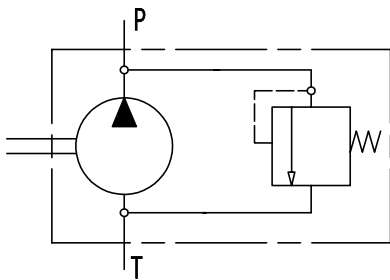

Spring CODE	Pressure setting range bar (psi)
<b>G</b>	101 – 150 (1465 – 2175)

Ordering example (add at the end of the pump or motor code) : RIFG(120)

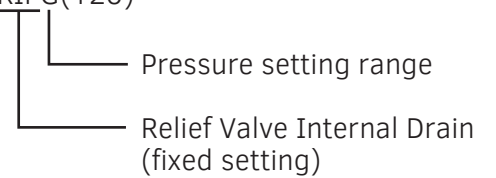

**OPTIONS**

Code **CH4** T2 EUROPEAN TAPERED SHAFT 1:8

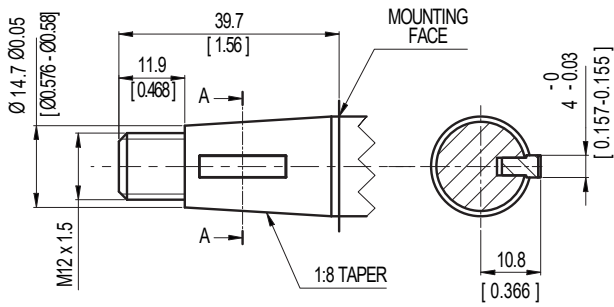

Max Torque = 140 Nm ( 1240 lbf in)

Code **FSD** SIDE DRAIN ON FLANGE

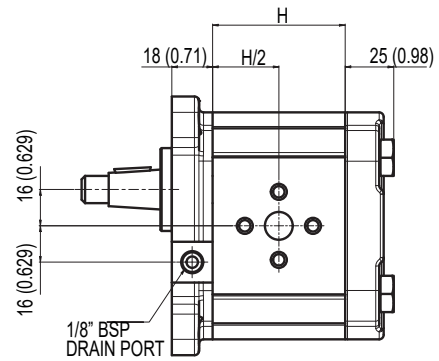

Code **SD** SIDE DRAIN ON COVER

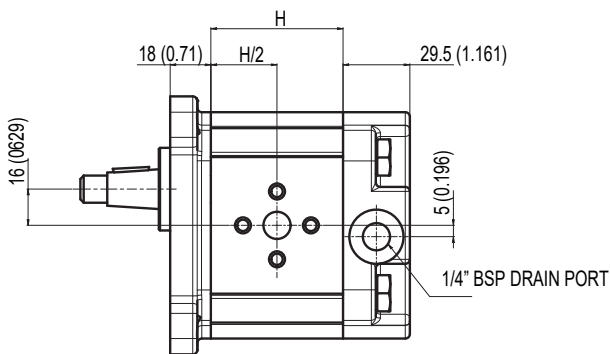

Code **AV** ANTICAVITATION VALVE FOR SINGLE ROTATION MOTOR

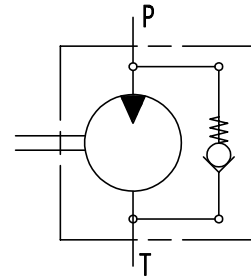

Code **ID** INTERNAL DRAIN FOR REVERSIBLE UNITS

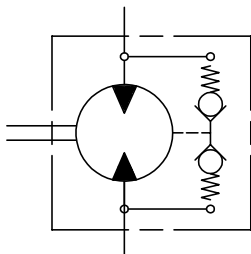

## UNITS ROTATING CHANGING INSTRUCTIONS

- A. Clean the pump externally with care
- B. Coat the sharp edges of the drive shaft ( 2 ) with adhesive tape and smear a layer of clean grease on the shaft and extension to avoid damaging the lip of the shaft seal when removing the mounting flange
- C. Lay the pump on the working area in order to have the mounting flange turned upside.
- D. Loosen, and remove, the clamp screws ( 1 ).
- E. Remove the mounting flange ( 3 ), taking care to keep the flange as straight as possible during removal.
- F. Ensure that while removing the front mounting flange, the drive shaft and other components remain in position.
- G. Ease the drive gear ( 2 ) up to facilitate removal of bearings ( 4 ), taking care that the precision ground surfaces do not become damaged, and removed the drive gear
- H. Remove the driven gear ( 2 ) without overturning. The rear flange has not to be removed.
- I. Re-locate the driven gear in the position previously occupied by the drive gear ( 2 ).
- J. Re-locate the drive gear ( 2 ) in the position previously occupied by the driven gear ( 5 ).
- K. Re-locate the bushing ( 4 ) without rotating. Refit the front mounting flange ( 3 ) turned by 180°.
- L. Refit the clamp screws ( 1 ). SCREW TIGHTENING TORQUE =  $60 \pm 2 \text{Nm}$  - M10
- M. Check that the pump rotates freely when the drive shaft ( 2 ) is turned by hand.
- N. If not a pressure plate seal may be pinched.
- O. The pump is ready for installation with the new direction of rotation.

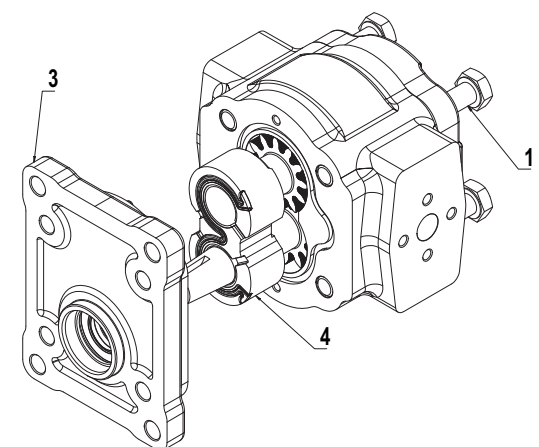
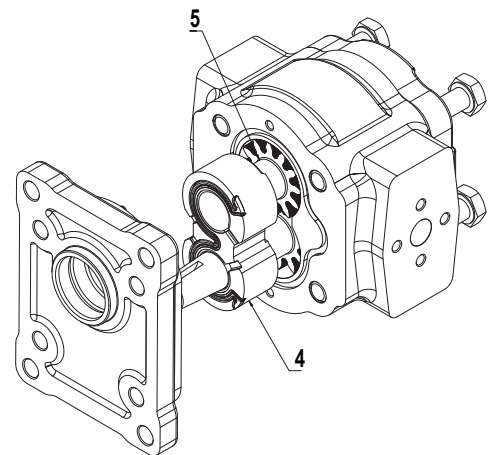
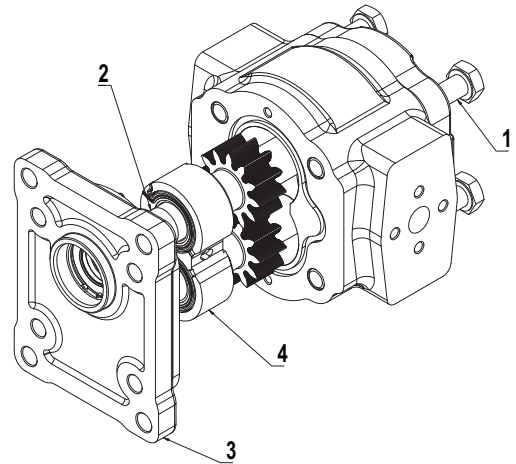

Supported by a worldwide network



## CONTACT INFORMATION

### EMEA

<b>GERMANY</b>	Hydreco Hydraulics GmbH, Straelen (NRW)	☎ +49 283494303-41	✉ info-de@hydreco.com
<b>ITALY</b>	Hydreco Hydraulics Italia Srl, Vignola (MO)	☎ +39 059 7700411	✉ sales-it@hydreco.com
<b>ITALY</b>	Hydreco Hydraulics Italia Srl, Parma (PR)	☎ +39 0521 1830520	✉ sales-it@hydreco.com
<b>ITALY</b>	Hydreco Srl, San Cesario S/P (MO)	☎ +39 059 330091	✉ cylinders@hydreco.com
<b>NORWAY</b>	Hydreco Hydraulics Norway AS, Nittedal	☎ +47 22909410	✉ post-no@hydreco.com
<b>UK</b>	Hydreco Hydraulics Ltd, Poole, Dorset	☎ +44 (0) 1202 627500	✉ info-uk@hydreco.com

### AMERICAS

<b>NORTH/LATIN</b>	Hydreco Inc/ Continental Hydraulics Inc, Shakopee (MN)	☎ +1 952 895 6400	✉ sales@conthyd.com
--------------------	--	-------------------	---------------------

### APAC

<b>AUSTRALIA</b>	Hydreco Hydraulics Pty Ltd, Seven Hills (NSW)	☎ +61 2 9838 6800	✉ sales-au@hydreco.com
<b>AUSTRALIA</b>	Hydreco Hydraulics Pty Ltd, Welshpool (WA)	☎ +61 8 9377 2211	✉ reception-wa@hydreco.com
<b>INDIA</b>	Hydreco Hydraulics India Private Ltd, Bangalore	☎ +91 80 67656300	✉ sales-in@hydreco.com

