

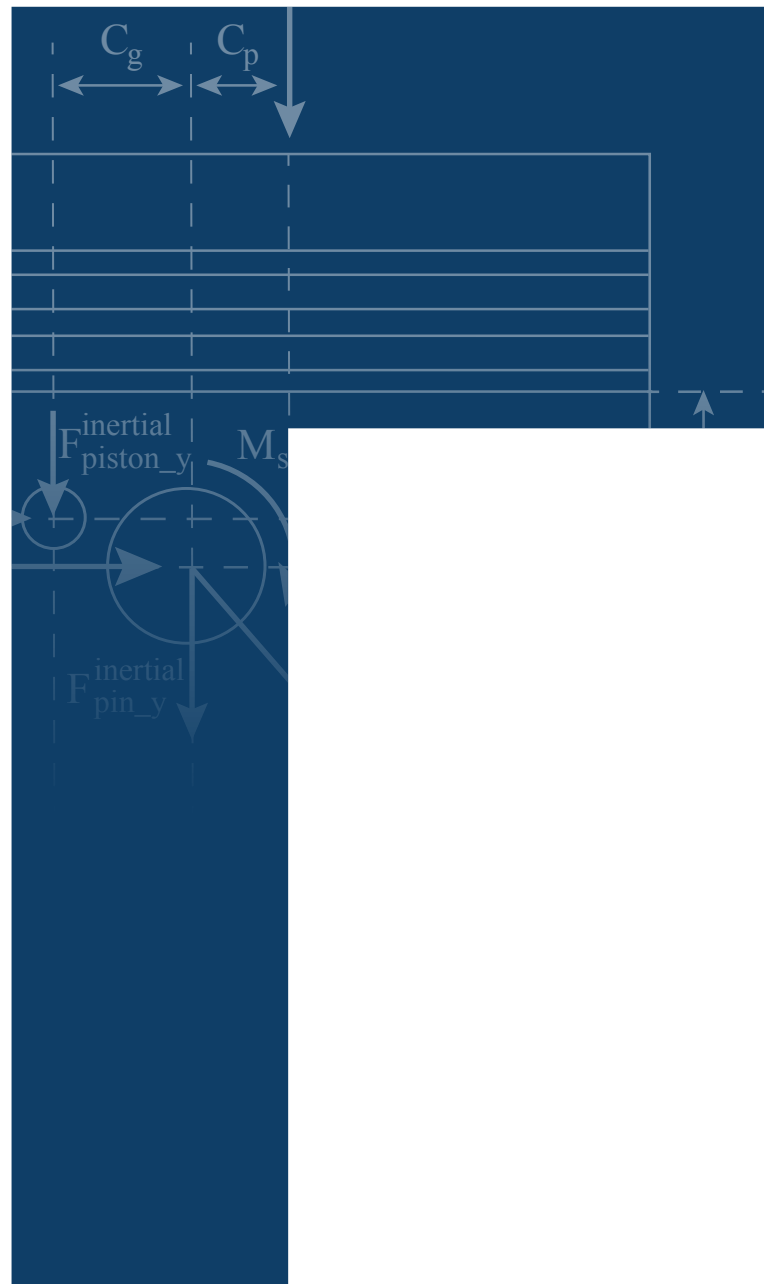

TILL

HYDRAULIK

*a member of **DAIKIN** group*

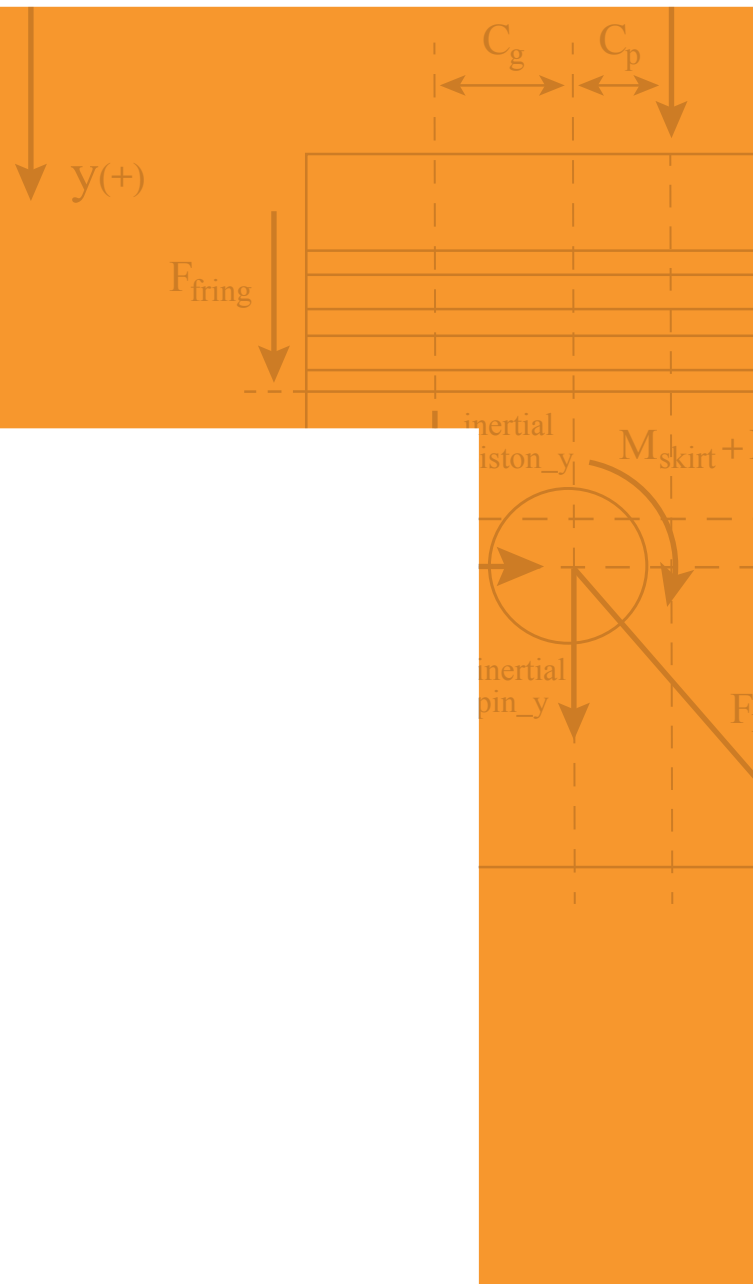

HIGH FORCE | COMPACT SIZE
EXTRAORDINARY PERFORMANCE

MICROHYDRAULICS CATALOGUE









TILL HYDRAULIK

a member of **DAIKIN** group





	Till Hydraulik	4
	Microhydraulics	6
	Application Examples	7
	Cylinders	8
	ME Rolled Micro-cylinders, single acting	9
	MD Rolled Micro-cylinders, double acting	17
	Valves	24
	MWV Micro Directional Valves	25
	MRV Micro Pilot-Operated Check Valves	29
	MDB Micro Direct Relief Valves	33
	MSR Micro Flow Control Valves	37
	MPR Micro Check Valves	41
	Subplates	44
	MGP Microhydraulic Subplates	45

TILL HYDRAULIK

Integrated into the Diplomatic Group, member of Daikin, we stand for **more than 60-year history in mobile hydraulics**.

As a medium-sized German company, **based in Helmstedt**, we develop the most efficient products, innovative components, and sophisticated system solutions to cover everything from the prototype to readiness for series production to servicing throughout the entire working life.

We assign great importance to excellent training and involvement of our employees.

We have a proven track record and experience gained over the decades in many projects in several industries.

*“With the region
in the heart,
we deliver solutions
for the whole world!”*

Product range

Till Hydraulik is the specialist for the implementation of special customer requirements in small and large series. Our hydraulic solutions can be found in applications for medical technology, agriculture, construction machinery, work platforms and much more. We are also able to apply our experience to special requirements such as the hydraulic rear wing adjustment of a sports car.

Our products portfolio includes:

1. Cylinders
2. Valves/Controls
3. Microhydraulics
4. Manual Compact Drives
5. Systems
6. Service & Spare Parts

When it comes to oil hydraulics, we find the solution!



Development

We develop special solutions according to the requirements of our customers. In addition, we have a wide range of catalog parts that are suitable for many applications.

Order by catalogue or send us your request, **we will be happy to help!**

Manufacturing

We meet the highest requirements for cleanliness. Assembly in our plants is standardized and guided.

Each product is documented and tested, neatly packaged and labeled according to customer requirements.



Service

As a manufacturer, we have the best experience for repairs, troubleshooting, maintenance and on-site operations.

Thanks to our workshop team and mobile service technicians, we ensure that your systems remain operational. We have various test benches for cylinders or valves, which are operated by our experienced personnel.

In case of extremely difficult situations, our engineering team can find the best solution for you.

On site, we can react flexibly and quickly through our well-equipped mobile service cars.

Do you need our support for maintenance or repair? **Talk to us!**

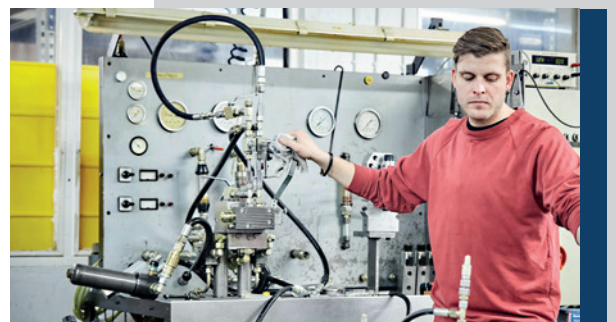

MICROHYDRAULICS

Microhydraulic technology enables the production of high forces in **highly compact designs**.

Till valves and control technology and its hydraulic cylinders are designed for a wide range of application fields.

Main features of microhydraulic systems

- Nominal size from 2 to 4
- Cylinders with stroke up to 300 mm
- Qmax 8 l/min
- Pressure ranges up to 250 bar
- Free of oil leakage
- Supply voltage 12 / 24 / 48 VDC



APPLICATION EXAMPLES

Med tech

When we are developing and manufacturing our products, we require them to meet the same high standards that patients expect from doctors. **High precision combined with easy operation is crucial in medical technology.**

Many functions that provide mobility must be performed in compact spaces. Till products provide electro-hydraulic appliances for operating tables such as base-break mechanism, lifting and tilting movements.

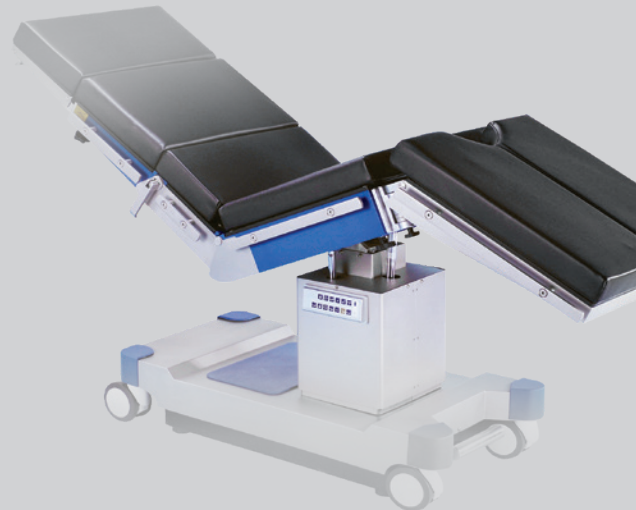

Special applications

Thanks to its reliable, resistant and compact qualities, microhydraulic systems are valuable in many high-demanding applications such as marine, automotive and robotic technology.

Whether you have to control the adjustment of a spoiler on a performance car or lift a stretcher aboard of a vehicle, **Till can provide the solution.**





CYLINDERS

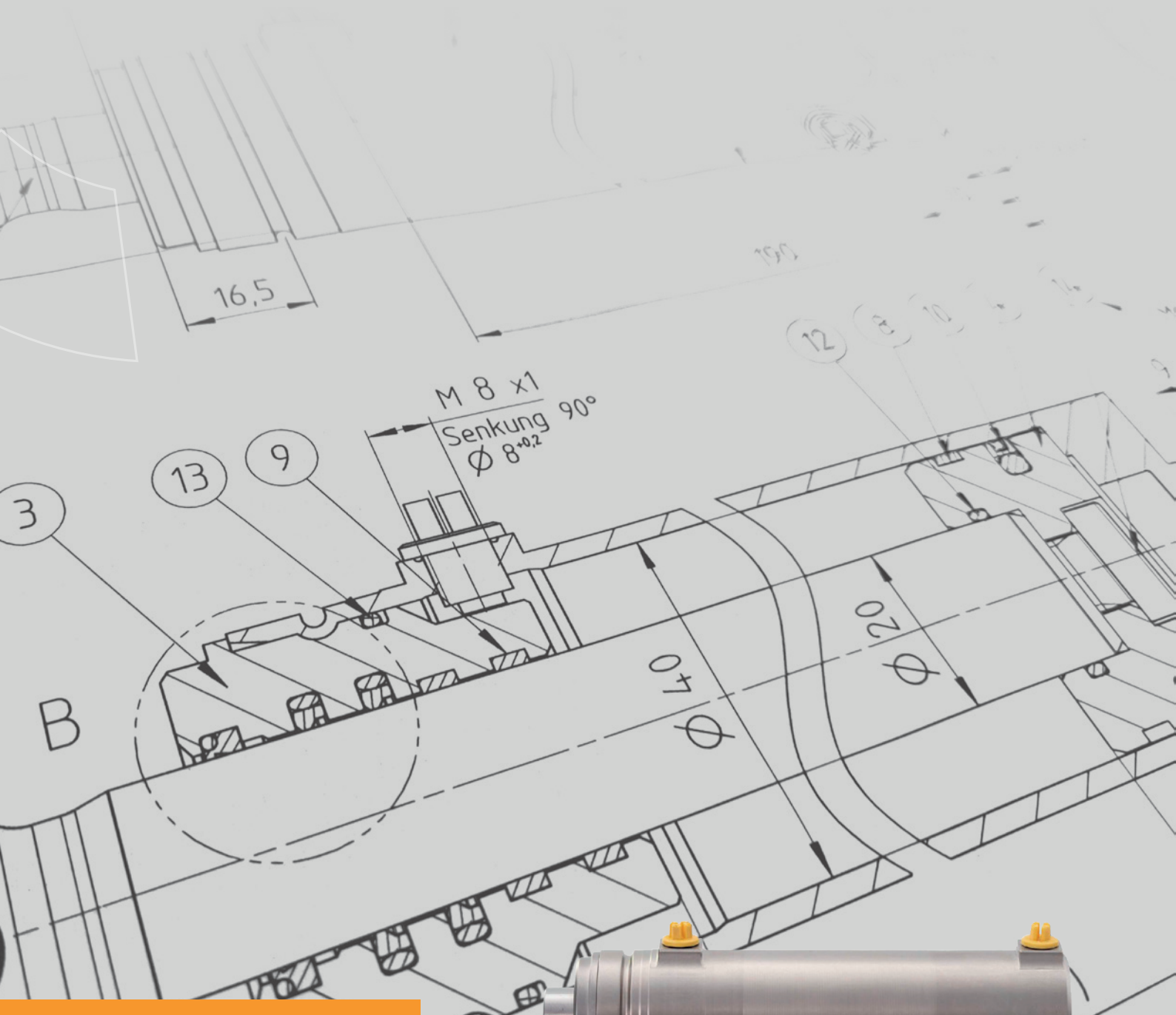

ME Rolled Micro-cylinders, single acting

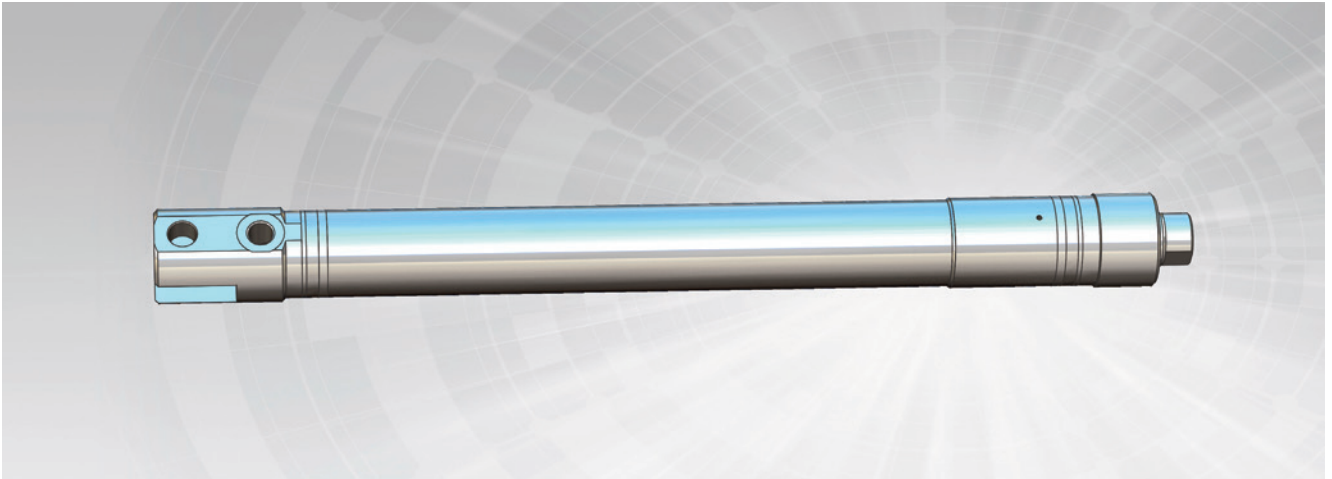

The ME hydraulic micro-cylinders have very thin wall thicknesses and can generate the highest forces in the smallest space.

All individual parts are designed for a very long service life.

The smooth surfaces of the cylinder barrel guarantee the lowest wear of seals. Cylinder barrels with a stroke of up to 300 mm are made of stainless materials with rolled guide bushing and rolled rear end.

Main features

- Piston sizes Ø20 mm, Ø25 mm
- Strokes up to 300 mm
- Max operating **pressure 160 bar**
- **Disconnected piston rod** with vent hole on the ring side
- Installation position with **pressing upwards**
- **Corrosion-resistant stainless** materials and/or coatings
- Geometries adapted to the **customer installation needs**
- Compact design for small installation spaces
- **Sealing capacity tested** with air pressure $\Delta p \leq 5 \text{ Pa/s}$
- Manufactured in **small, medium or large batches**

Hydraulic symbol

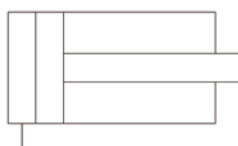

Order Code

1	2	/	3	-	4	-	5	/	6
ME									

1 Version
ME Single acting micro-cylinder

2 Piston diameter (mm)
020 Ø20
025 Ø25

3 Piston rod (mm)
16 Ø16
20 Ø20

4 Stroke length (mm)
max 300 mm

5 Rear mounting style
00 Without
ZB Through hole
ZG Clevis

6 Rod end mounting style
00 Without
KF Female thread
KM Male thread
KB Through hole (not available for piston rod Ø16)

Ordering example

Micro cylinder, single acting with piston diameter 20 mm, piston rod 16 mm, stroke 200 mm, clevis fixing on rear side and rod end with M8 female thread.

ME020/16-300-ZG/KF



Mounting styles overview

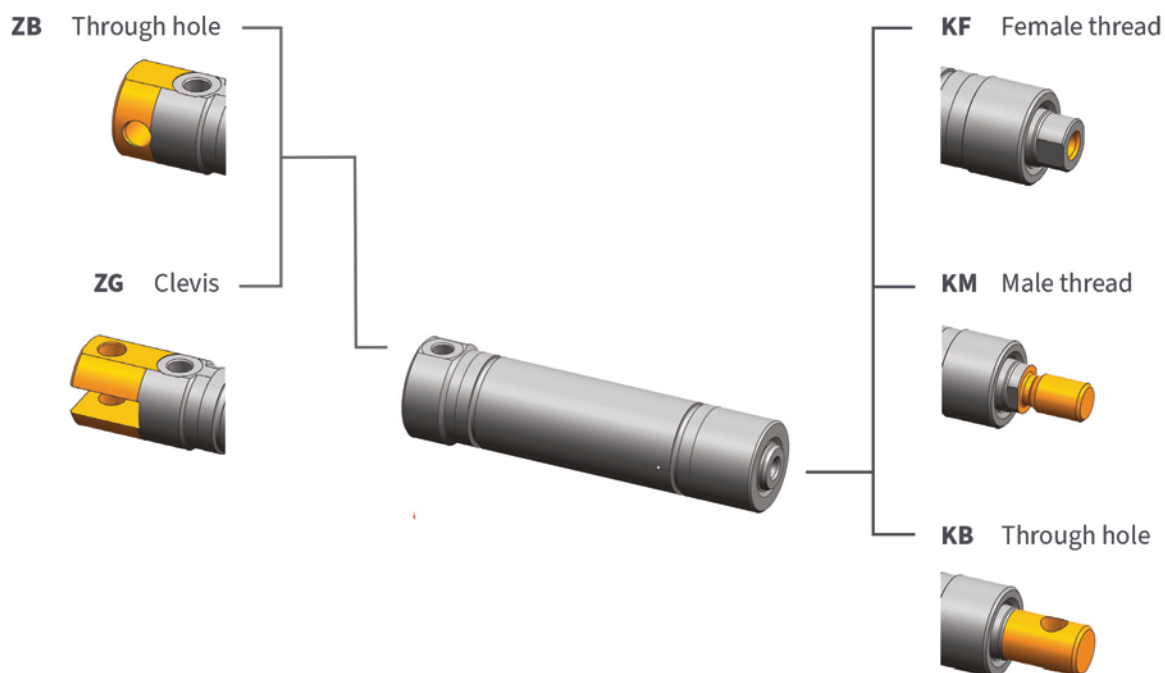

Technical data

Hydraulic oil: type contamination degree	HLP 32 (according to DIN 51524-2) filtered 10 µm ISO 4406:2021 class 18/16/13
Temperatures: operating (fluid) ambient, during operation transport and storage	from +10 °C to +80 °C from -10 °C to +60 °C from -20 °C to +70 °C
Materials	Our standard is stainless steel, diameter tolerance ISO f7; surface roughness: Ra max 0.25 µm We are able to supply cylinders made of other types of steel.
Safety requirements	According to ISO 4413:2010 - Hydraulic fluid power — General rules and safety requirements for systems and their components. The system operating pressure must be guaranteed by a safety valve (pressure relief valve).

Dimensions

Basic dimensions (without mounting options)

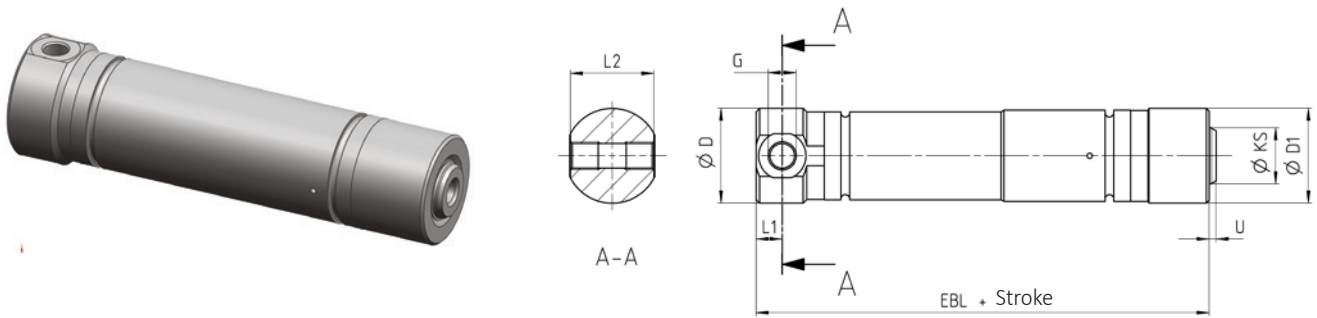

dimensions in mm

Piston	KS	ØD	ØD1	U	L1	L2	G	EBL
Ø20	Ø16	27	27	2	7,5	23,9	M8x1	89,5
Ø25	Ø16	35	32	2	7,5	33	M8x1	89,5
Ø25	Ø20	35	32	2	7,5	33	M8x1	89,5

Piston	Rod	Area ratio	Force at 100 bar (in kN)		Volume at 100 mm stroke (in L)
			Push		Piston side
Ø20	Ø16	2,78	3,14		0,03
Ø25	Ø16	1,69	4,91		0,05
Ø25	Ø20	2,78	4,91		0,05

Rod end mounting style

KF Female thread



dimensions in mm

Rod	SW	M	L	L1
Ø16	13	M8	28	8
Ø20	17	M10	28	8



KM Male thread

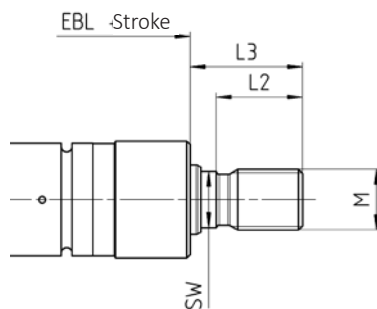

dimensions in mm

Rod	SW	M	L2	L3
Ø16	13	M12	20	26
Ø20	17	M16	20	26

KB Through hole

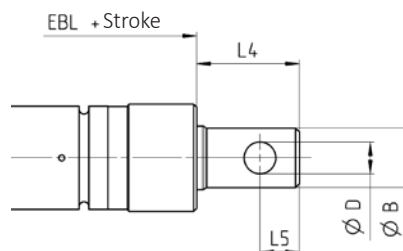

dimensions in mm

Rod	ØD	ØB	L4	L5
Ø20	10	19	26	10

Rear end mounting

ZB Through hole

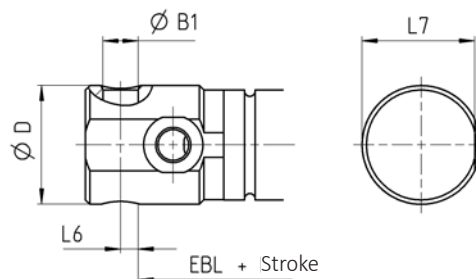

dimensions in mm

ØPiston	ØD	B1	L6	L7
20	27	8	4	25,65
25	35	10	5	34

ZG Clevis

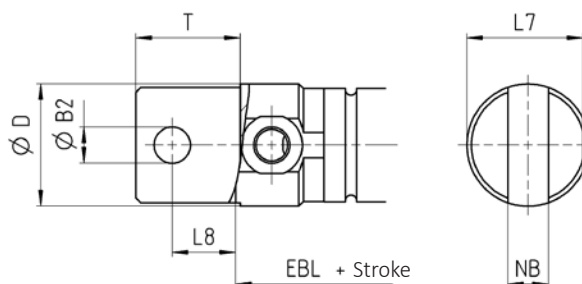

dimensions in mm

ØPiston	ØD	T	NB	ØB2	L7	L8
20	27	23	9	8	25,65	14
25	35	25	10	10	34	16,5



Operating and Maintenance Notes

Before the start-up of the hydraulic cylinders please observe the following instructions and the additional operating instructions for special cylinders, especially when dealing with systems and telescopic cylinders.

i Safety Instructions

A hydraulic cylinder has two main functions: the one of pressure vessel during the process or when under load, and the one of moving element. Therefore, close attention must be paid to the following points:

- installation may only be carried out by a hydraulic specialist
- the operating pressure must be secured by a safety valve (pressure relief valve)
- the DIN EN ISO 4413 safety standard for hydraulics must be observed

ii Assembly and Installation

assembly:

- all screw connections for fixing should comply with DIN ISO 898-1 of strength class 8.8 (recommended 10.9).
- pay attention to the cleanliness of the hydraulic cylinder and of the surrounding environment.
- before the start-up, bleed the hydraulic cylinder.
- the operating fluid must be compatible with the sealing material. Sealants such as hemp, putty or sealing tape are forbidden.
- before the installation, raw pipes and tanks must be cleaned from dirt, rust, sand, chips, etc.
- hot-bent or welded pipes must be pickled, rinsed and lubricated.

installation:

- the pressure in the hydraulic cylinder must not exceed the specified maximum pressure.
- the maximum admissible stroke length must be observed when selecting the hydraulic cylinder. Therefore, mounting type, installation position and maximum operating pressure must be considered.
- the hydraulic cylinder must be mounted tension-free. Lateral forces must result neither from the cylinder mounting side nor from the load (rod end).

iii Start-up

bleeding: before the start-up, bleed the air from the hydraulic cylinder.

operating medium:

- all Till Hydraulik's cylinders are suitable for hydraulic oils HLP according to DIN 51524-2.
- check whether the pressure fluids of the system match the permissible pressure fluids of the hydraulic cylinder.
- the maximum temperatures recommended by the fluids manufacturer should not be exceeded. It is recommended to keep the fluid temperature constant to ensure a steady response of the system.

Maintenance

The hydraulic cylinders are maintenance-free. Pay attention to lubrication of the mounting points.

Storage Room Requirements

Hydraulic cylinders should be stored in a dry, dust-free environment, far from etching materials and vapors.

SMALL COMPACT SIZE

HIGH FORCE

EXTRAORDINARY PERFORMANCE



MD Rolled Micro-cylinders, double acting

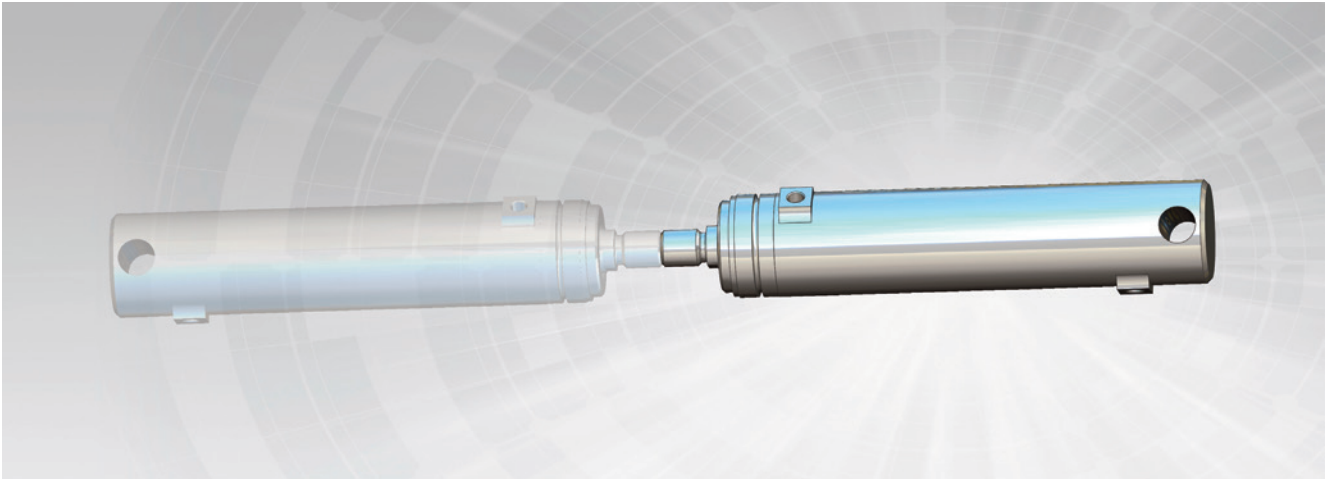

The MD hydraulic micro-cylinders have very thin wall thicknesses and can generate the highest forces in the smallest space.

All individual parts are designed for a very long service life.

Cylinder barrels are bored up to 150 mm from a solid metal piece and have rolled guide bushing.

Main features

- Piston sizes Ø32 mm, Ø40 mm, Ø50 mm
- Strokes up to 150 mm
- Max operating **pressure 160 bar**
- **Corrosion-resistant stainless** materials and/or coatings
- Redundant sealing systems to obtain "**dry hydraulics**"
- Geometries adapted to the **customer installation needs**
- Compact design for small installation spaces
- **Sealing capacity tested** with air pressure $\Delta p \leq 5 \text{ Pa/s}$
- Any installation position
- Manufactured in **small, medium or large batches**

Hydraulic symbol

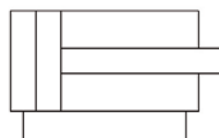

Order Code

1	2	3	4	5	6	7	8	9
MD		20						

1 Version
MD Double acting cylinder

2 Piston diameter (mm)
032 Ø32
040 Ø40
050 Ø50

3 Piston rod (mm)
20 Ø20

4 Stroke length (mm)
max 150 mm

5 Rear mounting style
00 Without
ZB Through hole
ZG Clevis

6 Rod end mounting style
00 Without
KF Female thread
KM Male thread
KB Through hole
KGB Sphere with trough hole

7 Thread size of rod end
(option for KF and KM fastening only)
10 M10
16 M16

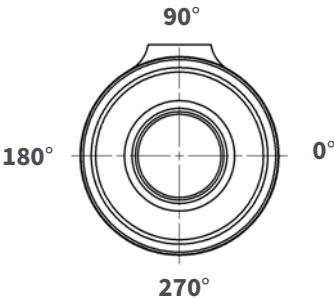
8 / 9 Ports position rear / front
<p>view on piston rod</p>  <p>90° 180° 0° 270°</p> <p>090 / 090 both ports face upwards (90°) (standard) Every combination is possible, rotation angle is free</p>

Ordering example

Micro cylinder, double acting with piston rod diameter 20 mm, piston diameter 40 mm, stroke 115 mm, through hole fixing on rear side and rod-end with M16 male thread. Rear port at 90° and front port at 225°.

MD040/20-115-ZB/KM-16-090/225



Mounting styles overview

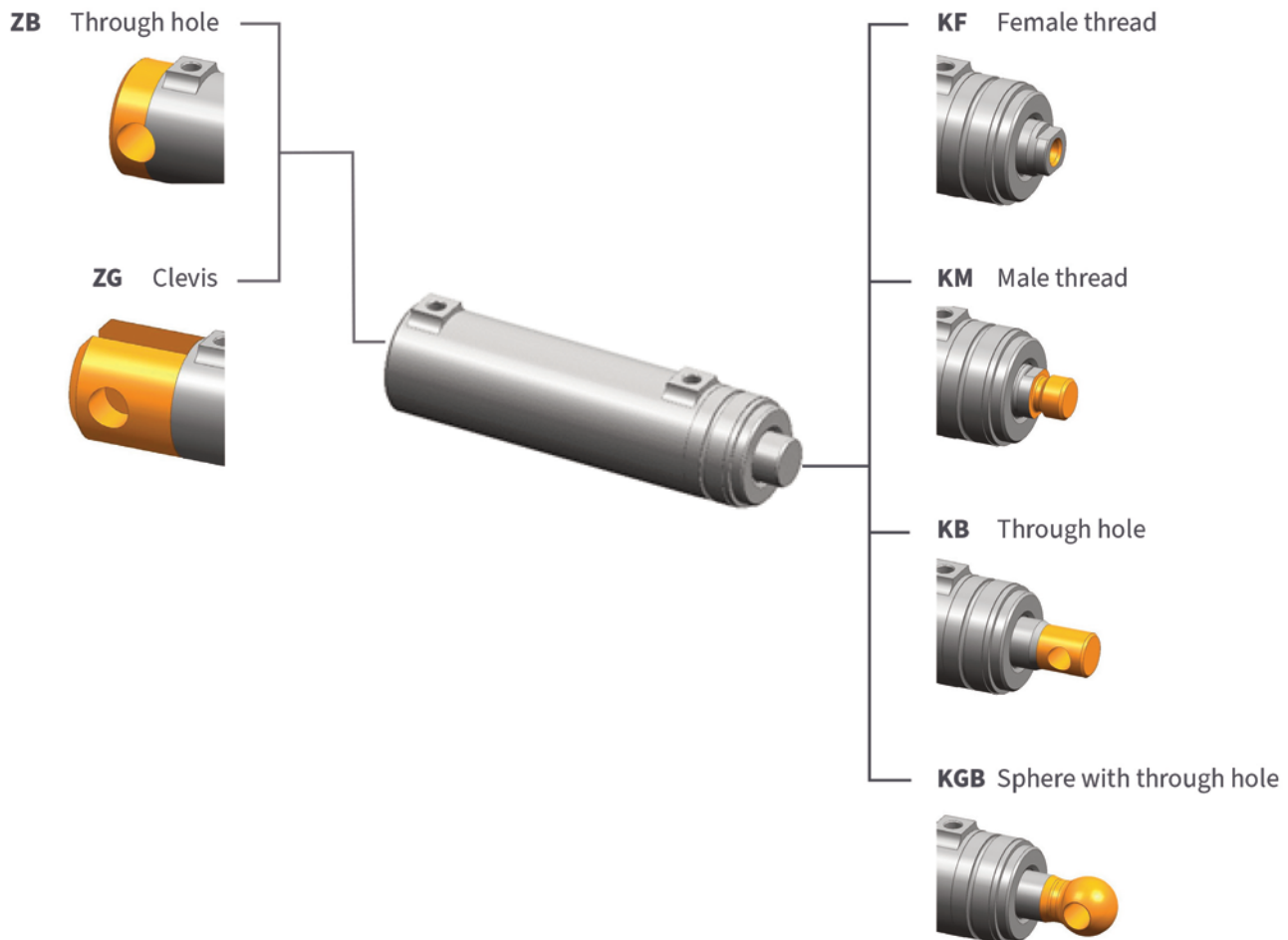

Technical data

Hydraulic oil: type	HLP 32 (according to DIN 51524-2) filtered 10 µm
contamination degree	ISO 4406:2021 class 18/16/13
Temperatures: operating (fluid)	from +10 °C to +80 °C
ambient, during operation	from -10 °C to +60 °C
transport and storage	from -20 °C to +70 °C
Materials	Our standard is stainless steel, diameter tolerance ISO f7; surface roughness: Ra max 0.25 µm We are able to supply cylinders made of other types of steel.
Safety requirements	According to ISO 4413:2010 - Hydraulic fluid power — General rules and safety requirements for systems and their components. The system operating pressure must be guaranteed by a safety valve (pressure relief valve).

Dimensions

Basic dimensions (without mounting options)

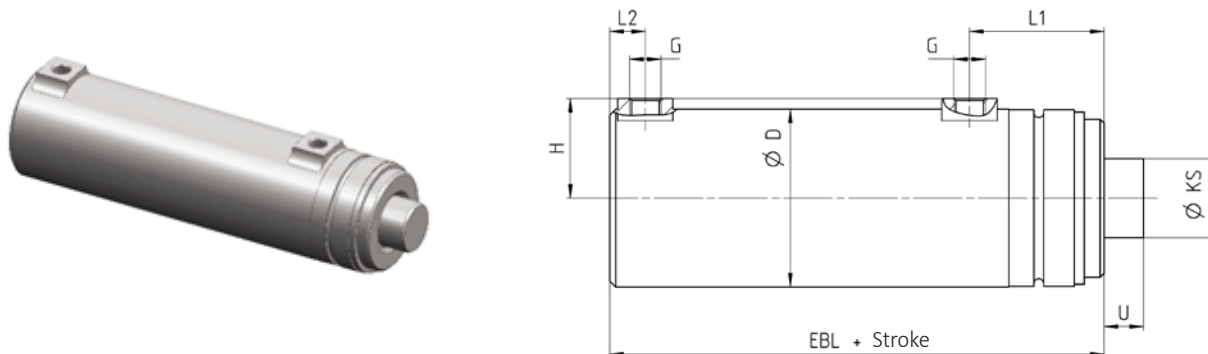

dimensions in mm

Piston	KS	U	ØD	L1	L2	H	G	EBL
Ø32	Ø20	10	40	34	11,5	23,7	M8x1	75
Ø40		10	45	34	11,5	25,2	M8x1	75
Ø50		10	58	34	11,5	31,5	M8x1	95

Piston	Rod	Area ratio	Force at 100 bar (in kN)		Volume at 100 mm stroke (in L)	
			Push	Pull	Rear	Front
Ø32	Ø20	1,64	8,04	4,90	0,08	0,05
Ø40		1,33	12,57	9,42	0,13	0,09
Ø50		1,19	19,63	16,49	0,20	0,16

Rod end mounting style

KF Female thread



dimensions in mm

Rod	SW	M	L	L1
Ø20	14	M10	17	6



KM Male thread

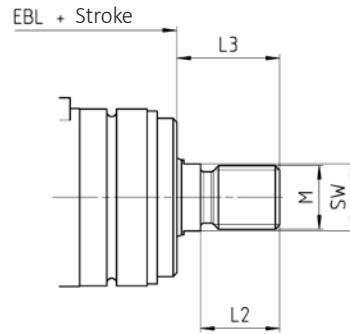

dimensions in mm

Rod	SW	M	L2	L3
Ø20	17	M16	20	26

KB Through hole

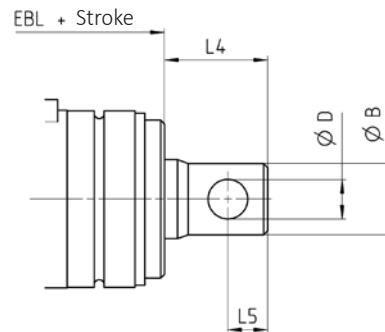

dimensions in mm

Rod	ØD	ØB	L4	L5
Ø20	10	19	26	10

KGB Sphere with through hole

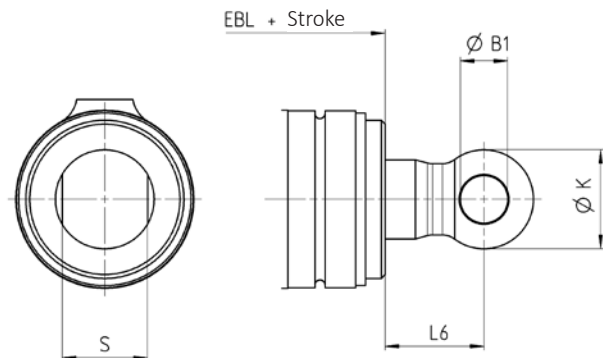

dimensions in mm

Rod	L6	ØB1	K	S
Ø20	24,5	12	25	21,6

Rear end mounting

ZB Through hole

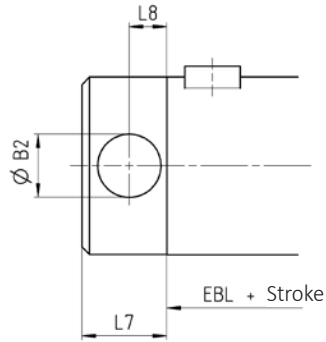

dimensions in mm

ØPiston	B2	L7	L8
32	12	21,5	10
40	16	21,5	12,5
50	16	21,5	12,5

ZG Clevis

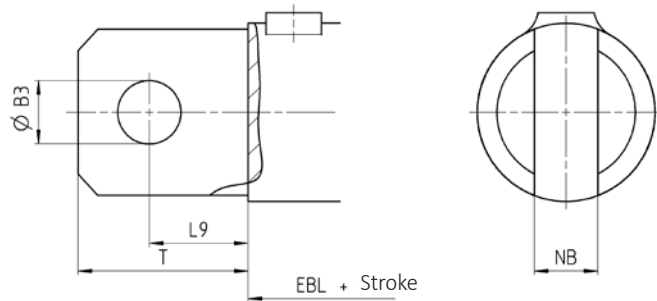

dimensions in mm

ØPiston	T	NB	ØB3	L9
32	32	11	12	25
40	43	11	12	25
50	43	16	16	33



Operating and Maintenance Notes

Before the start-up of the hydraulic cylinders please observe the following instructions and the additional operating instructions for special cylinders, especially when dealing with systems and telescopic cylinders.

i Safety Instructions

A hydraulic cylinder has two main functions: the one of pressure vessel during the process or when under load, and the one of moving element. Therefore, close attention must be paid to the following points:

- installation may only be carried out by a hydraulic specialist
- the operating pressure must be secured by a safety valve (pressure relief valve)
- the DIN EN ISO 4413 safety standard for hydraulics must be observed

ii Assembly and Installation

assembly:

- all screw connections for fixing should comply with DIN ISO 898-1 of strength class 8.8 (recommended 10.9).
- pay attention to the cleanliness of the hydraulic cylinder and of the surrounding environment.
- before the start-up, bleed the hydraulic cylinder.
- the operating fluid must be compatible with the sealing material. Sealants such as hemp, putty or sealing tape are forbidden.
- before the installation, raw pipes and tanks must be cleaned from dirt, rust, sand, chips, etc.
- hot-bent or welded pipes must be pickled, rinsed and lubricated.

installation:

- the pressure in the hydraulic cylinder must not exceed the specified maximum pressure.
- the maximum admissible stroke length must be observed when selecting the hydraulic cylinder. Therefore, mounting type, installation position and maximum operating pressure must be considered.
- the hydraulic cylinder must be mounted tension-free. Lateral forces must result neither from the cylinder mounting side nor from the load (rod end).

iii Start-up

bleeding: before the start-up, bleed the air from the hydraulic cylinder.

operating medium:

- all Till Hydraulik's cylinders are suitable for hydraulic oils HLP according to DIN 51524-2.
- check whether the pressure fluids of the system match the permissible pressure fluids of the hydraulic cylinder.
- the maximum temperatures recommended by the fluids manufacturer should not be exceeded. It is recommended to keep the fluid temperature constant to ensure a steady response of the system.

Maintenance

The hydraulic cylinders are maintenance-free. Pay attention to lubrication of the mounting points.

Storage Room Requirements

Hydraulic cylinders should be stored in a dry, dust-free environment, far from etching materials and vapors.



VALVES

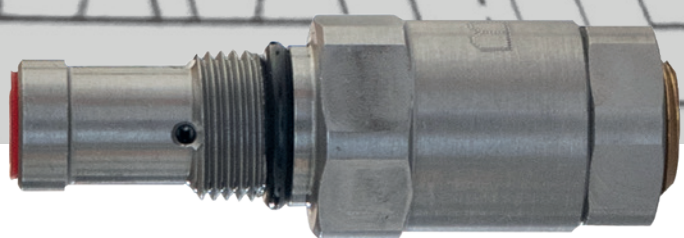
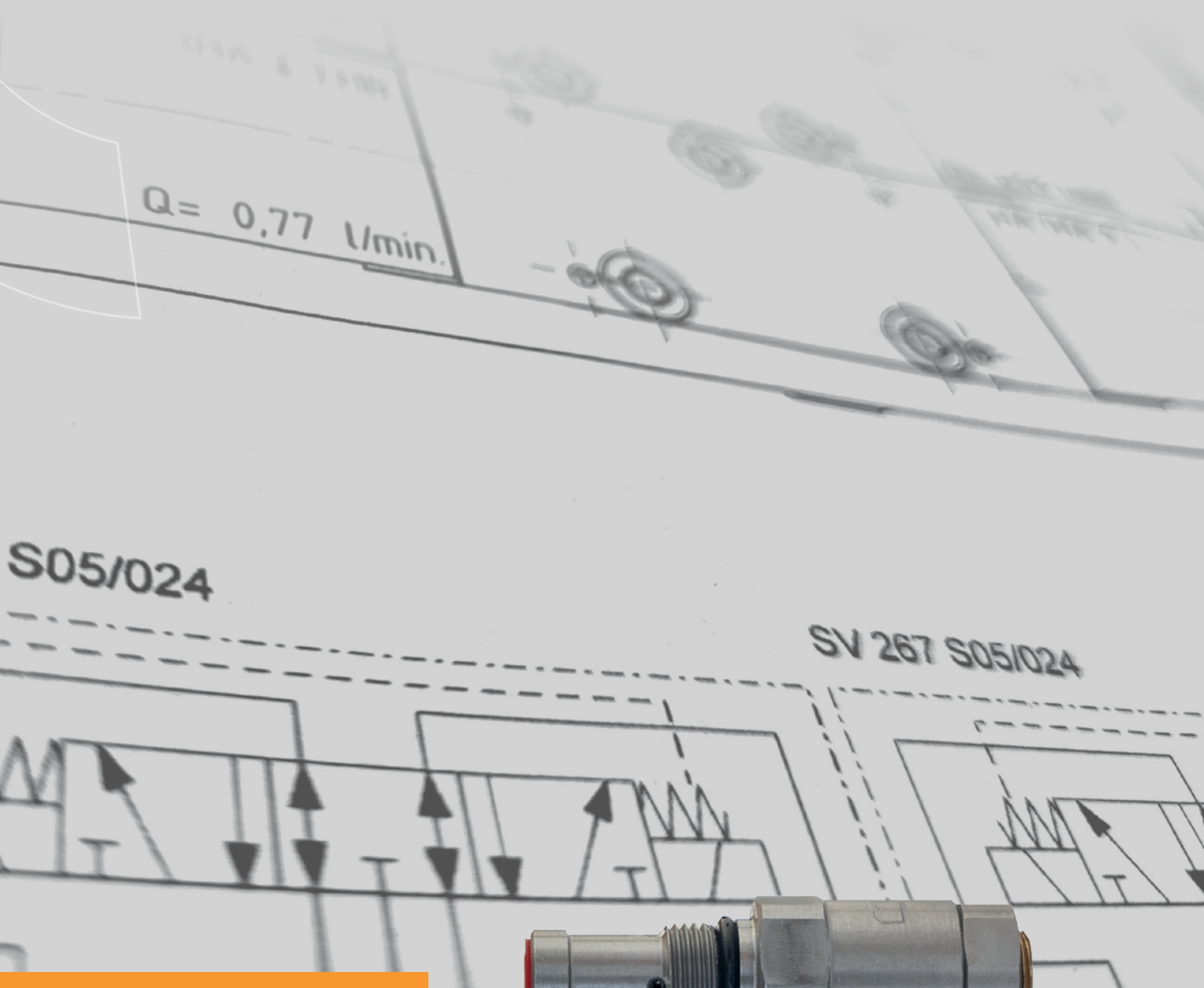

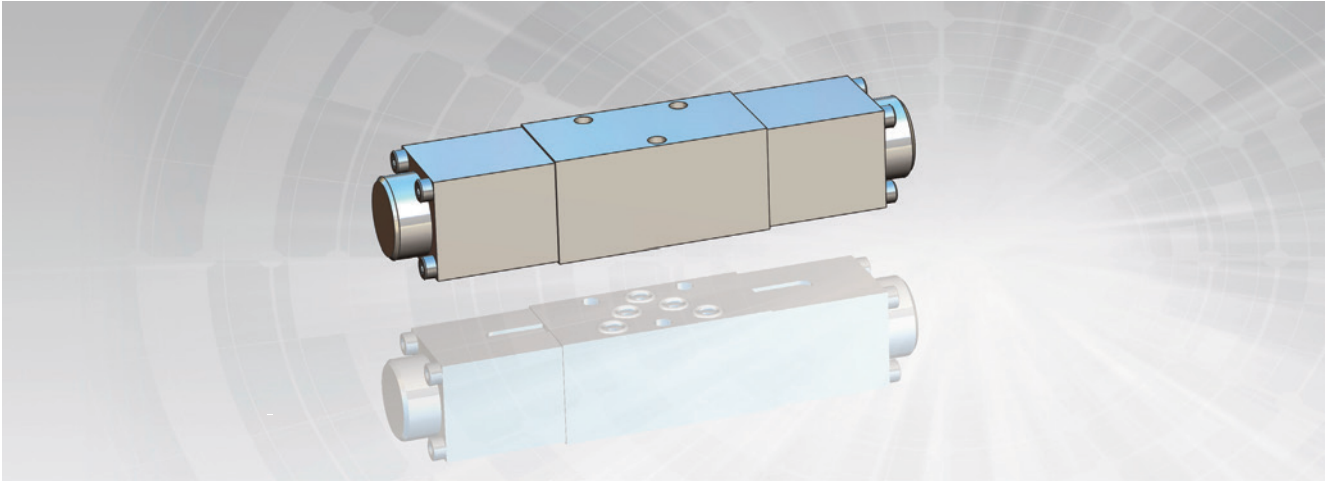

Micro-hydraulic valves in the design of 4/3-way valves in flanged construction are in spool design and are directly electromagnetically operated. They are also available in 4/2 way design. The hole pattern of the NG 3 corresponds to a widely used factory standard. See appendix. The valves have a hardened and ground piston and are fitted into the honed housing.

Main features

- Subplate design for stack mounting
- Max operating **pressure 250 bar**
- Max flow rate **5 l/min**
- Available valve voltages **12, 24 and 48 V DC**
- Coil connection by **outgoing cable** (AWG 22, UL listed), 720 mm long
- Corrosion resistant stainless materials and/or coatings
- Any installation position, preferably horizontal
- Manufactured in **small, medium or large batches**

Hydraulic Symbol

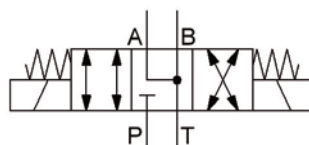

Order Code

1 2 3 4 5 6

MWV - - - -

1 Version

MWV Solenoid directional valve

2 Valve version

S 2 solenoids, 3 positions, spring centering
SA 1 solenoid on side A, 2 positions, spring return
SB 1 solenoid on side B, 2 positions, spring return

3 Spool type

look at page 3, 'available spools' section

4 Seals

N NBR seals (**Standard**)
V FPM seals

5 Supply voltage

12 12 V DC
24 24 V DC
48 48 V DC

6 Position of lead wires

- 0** mounting surface side
- 1** 90° - valve front (path pressure side)
- 2** 180° - opposite to the mounting surface (upwards)
- 3** 270° - valve rear (path return side)

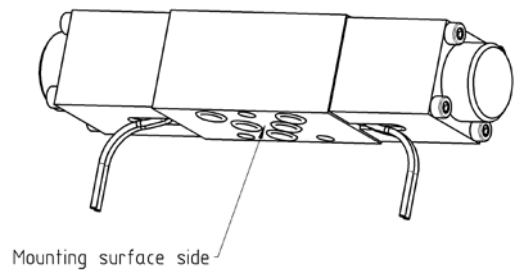

To choose the right orientation of the power supply cable, consider where the valve will be installed: coils are fixed to the valve in the factory, and it is not possible to disassemble them later to orient the cable.

on single station: position 1, 2 or 3
 on a single station above a check valve: all positions
 on multi-station base: position 2
 on multi-station base above a check valve: position 2 or 0

Ordering example

Micro directional valve, 3 positions, closed center, NBR seals, 24V supply voltage with both the lead wires on valve front.

MWV-S1-N24-1

Micro directional valve, 2 positions with actuation on side A, closed center, NBR seals, 24V supply voltage with both the lead wires upward.

MWV-SA1-N24-2



Available spools

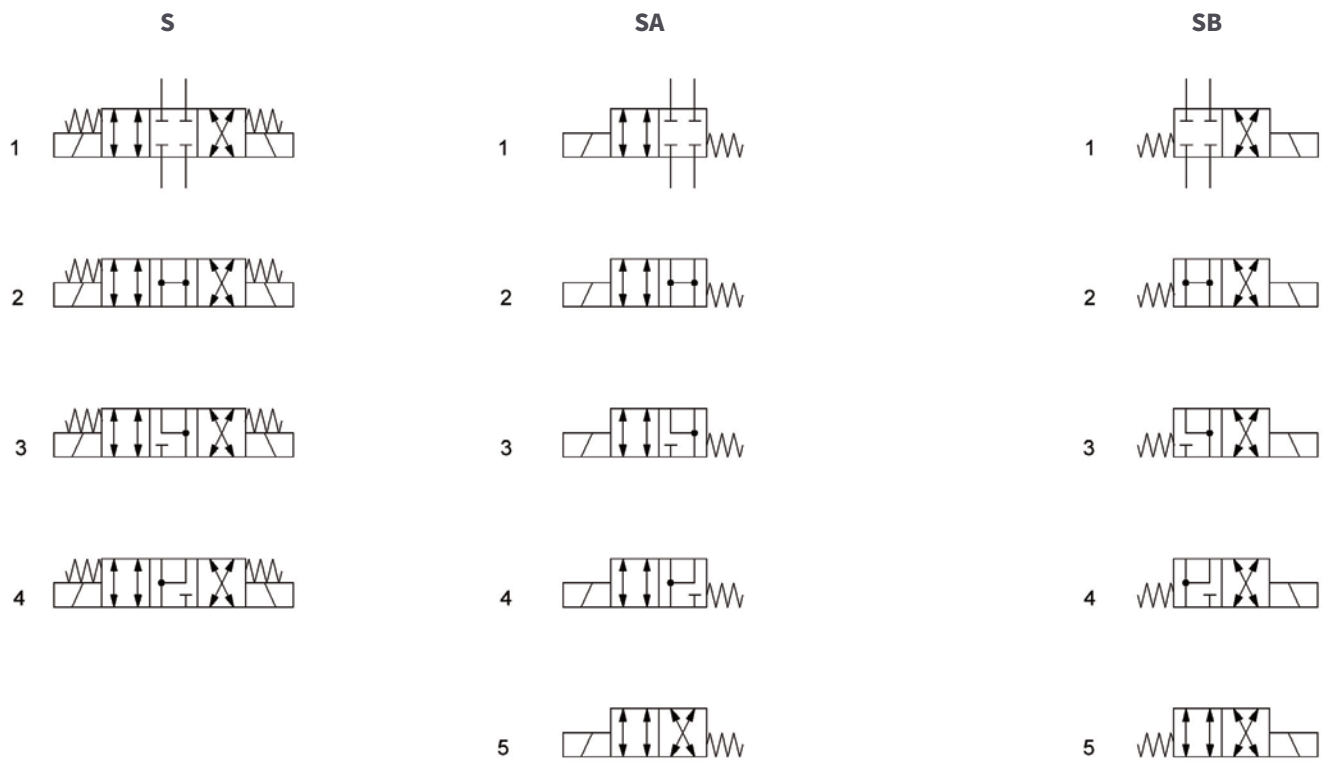

Technical data

Hydraulic oil: type	HLP 32 (according to DIN 51524-2) filtered 10 µm
contamination degree	ISO 4406:2021 class 18/16/13
Temperatures: operating (fluid)	from +10 °C to +80 °C
ambient, during operation	from -10 °C to +60 °C
transport and storage	from -20 °C to +70 °C
Material: valve body	brass
coil	steel, with zinc surface treatment
Safety requirements	According to ISO 4413:2010 - Hydraulic fluid power — General rules and safety requirements for systems and their components. The system operating pressure must be guaranteed by a safety valve (pressure relief valve).

Coils:	12 V DC	24 V DC	48 V DC
duty cycle	100%		
insulation class	F		
protection class	EN 60529 IP00		
Resistance [ohm]	8,28	32,86	133,63
Current consumption (A)	1,45	0,73	0,36
Power consumption [W]	17,4	17,5	17,3

Dimensions

Mounting interface

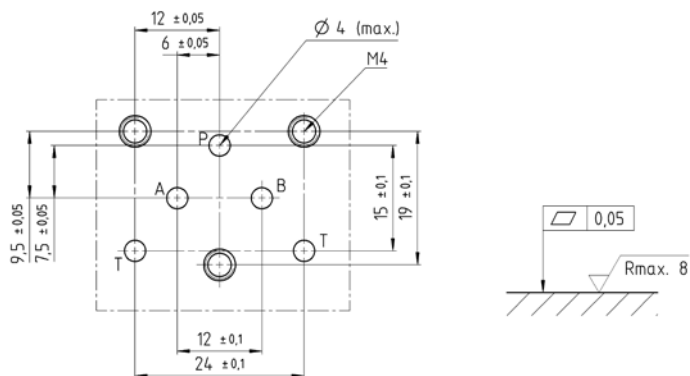

Installation

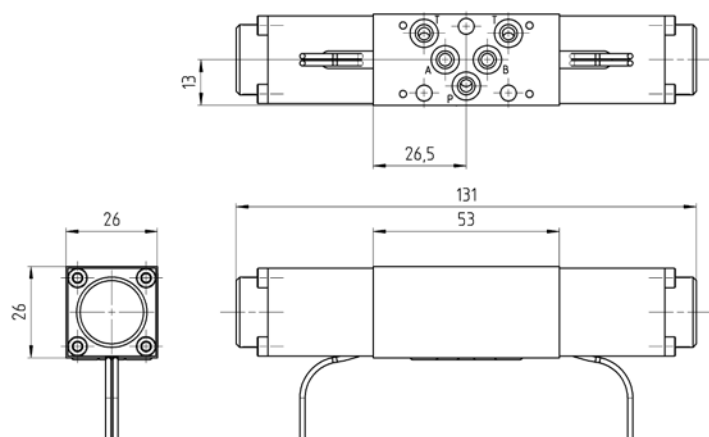

dimensions in mm

Seals	n° 5 O-ring 5x1,5 NBR 70 Shore A
Valve fastening	n° 3 SHC screws M4 ISO 4762 Tightening: 3 Nm (A2-70) Threaded holes: M4 min depth 9 mm

Subplates

See catalogue MGP_Microsubplates.



MRV Micro pilot-operated check-valves

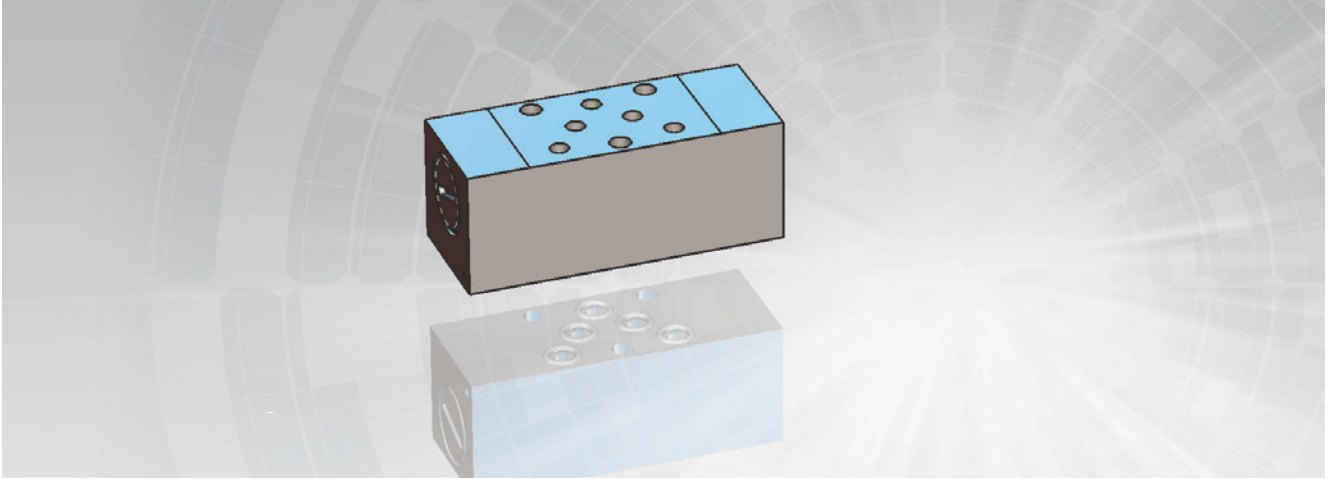

The MRV micro-hydraulic valve is a pilot-operated check-valve in flanged design. The valve is available as a twin valve with check function in both of the working lines. In addition, a pressure relief valve can be integrated.

The valve is used to compensate for leakage from directional control valves in spool design. High-quality material combinations and fatigue-resistant springs ensure a long, leak-free and dynamic service life.

Main features

- Subplate design for stack mounting
- Max operating **pressure 250 bar**
- Cracking pressure 2, 5, 11 or 25 bar
- Pilot ratio 1:3
- Max flow rate **5 l/min**
- Leakage free
- Stackable vertical with directional solenoid valves
- Corrosion resistant stainless materials and/or coatings
- Other cracking pressures available on request
- Manufactured in **small, medium or large batches**

Hydraulic Symbol

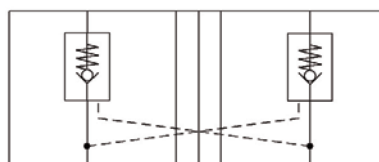

Order Code

1 2 3 4 5
 MRV - / - -

1 Version
MRV Pilot-operated check-valve, with spring

2 Leakage-free seal
D Both the working lines (standard)
SA Working line A
SB Working line B
DV Both the working lines. Pressure relief valve in A + B
DVA Both the working lines. Pressure relief valve in A
DVB Both the working lines. Pressure relief valve in B

3 Cracking pressure of the check valve
11 11 bar (standard)
2,2 2,2 bar
25 25 bar

4 Adjustment of the pressure relief valve (for DV, DVA and DVB versions only)
120 120 bar

5 Seals
N NBR seals (standard)
V FPM seals

Ordering example

Micro check-valve, both the working lines, 11 bar cracking pressure, NBR seals

MRV-D/11-N

Micro check-valve, both the working lines, pressure relief valve in A, 11 bar cracking pressure, 120 bar pressure relief valve, NBR seals

MRV-DVA/11-120-N

Hydraulic symbols

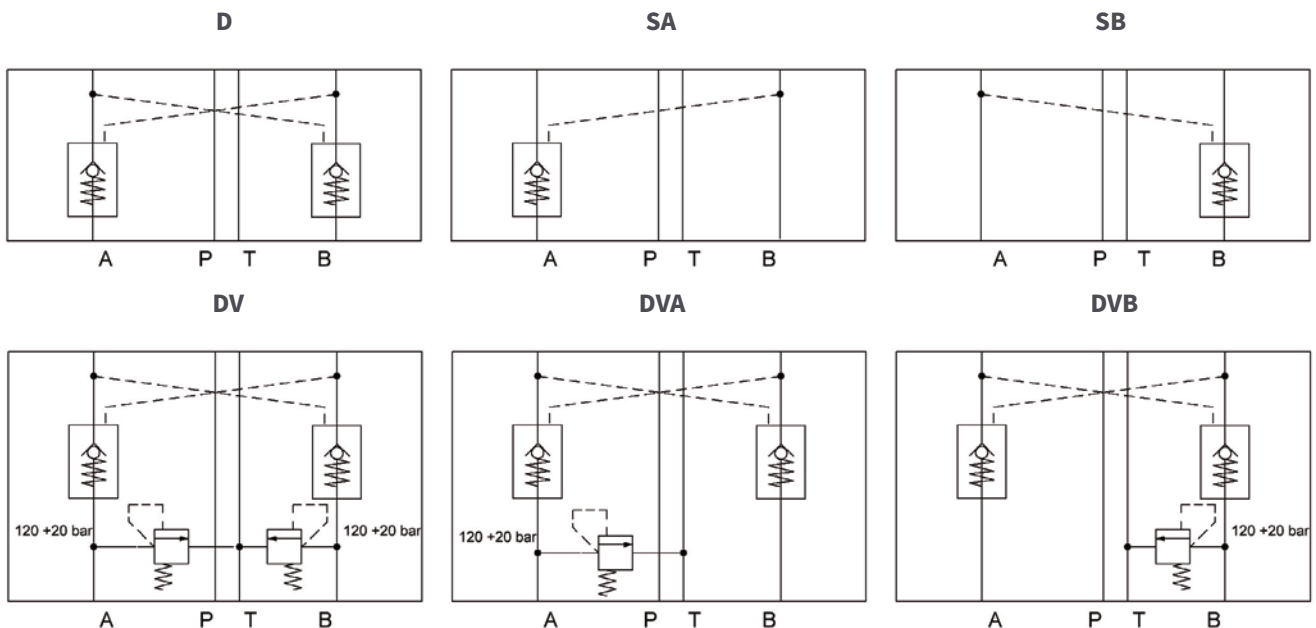

Technical data

Hydraulic oil: type	HLP 32 (according to DIN 51524-2) filtered 10 µm
contamination degree	ISO 4406:2021 class 18/16/13
Temperatures: operating (fluid)	from +10 °C to +80 °C
ambient, during operation	from -10 °C to +60 °C
transport and storage	from -20 °C to +70 °C
Material: valve body	brass
Safety requirements	According to ISO 4413:2010 - Hydraulic fluid power — General rules and safety requirements for systems and their components. The system operating pressure must be guaranteed by a safety valve (pressure relief valve).

Dimensions

Mounting interface

dimensions in mm

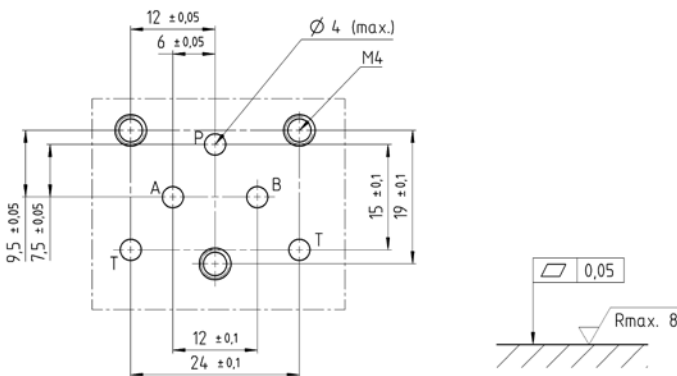

Installation

Type D / SA / SB

dimensions in mm

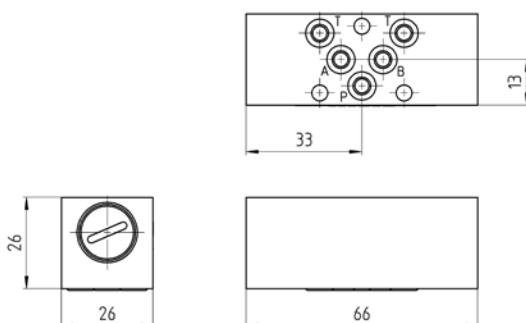

Type DV

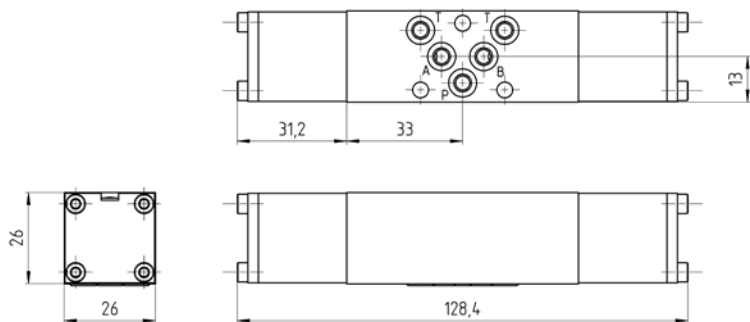

Type DVA / DVB

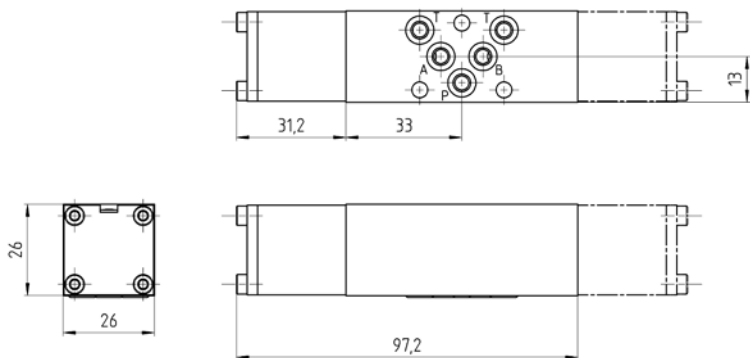

Seals	n° 5 O-ring 5x1,5 NBR 70 Shore A
Valve fastening	n° 3 SHC screws M4 ISO 4762 Tightening: 3 Nm (A2-70) Threaded holes: M4 min depth 9 mm

Subplates

See catalogue MGP_Microsubplates.



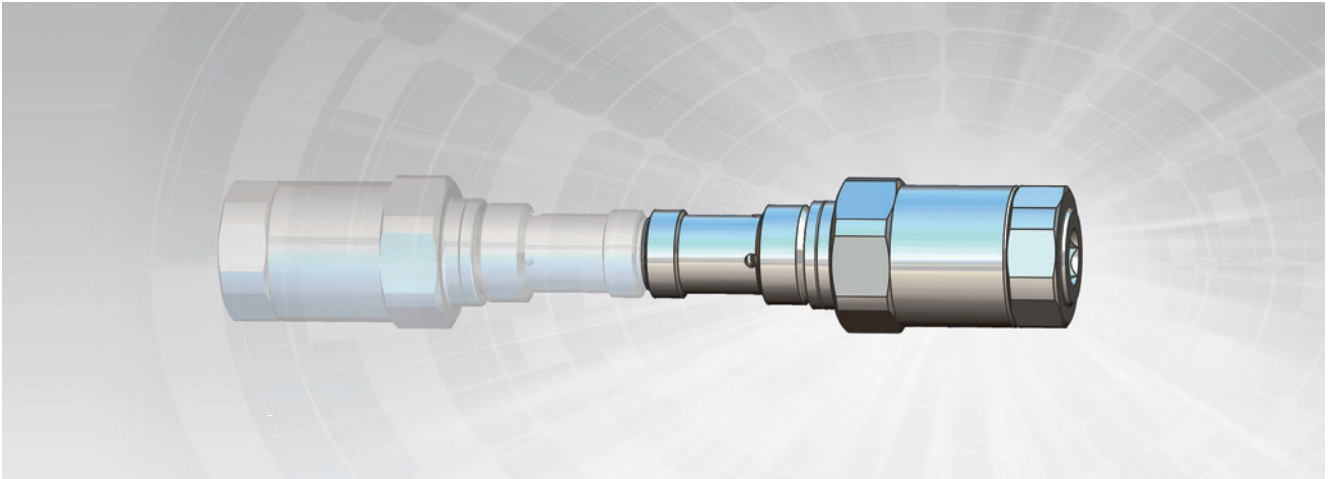

MDB are direct operated relief valves. If the applied pressure reaches the set value, the valve opens and allows the fluid to flow to the tank. If the pressure drops again, the valve closes with low hysteresis. The valve has a fast and precise response. The most important components are hardened and ground.

Main features

- Compact design
- Max operating **pressure 160 bar**
- Max flow rate **2 l/min**
- **Corrosion-resistant stainless** materials and/or coatings
- **Low-noise**
- Low hysteresis
- Desired pressure value **easy to adjust**
- Easy to adjust under pressure
- Flat p-Q characteristic curve
- Available preset upon request
- Manufactured in **small, medium or large batches**

Hydraulic Symbol

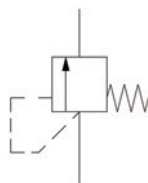

Order Code

1 2 3
MDB / -

1 Version
MDB Direct relief valve

2 Pressure set value (bar)
The pressure adjustment range is 60 to 160 bar. Choose the pressure set value.
A 80 bar C 130 bar
B 105 bar D 140 bar
E 123 bar

3 Seals
N NBR seals (Standard)
V FPM seals

Ordering example

Direct relief valve, 123 bar pressure set value, NBR seals.

MDB/E-N

Technical data

Hydraulic oil: type contamination degree	HLP 32 (according to DIN 51524-2) filtered 10 µm ISO 4406:2021 class 18/16/13
Temperatures: operating (fluid) ambient, during operation transport and storage	from +10 °C to +80 °C from -10 °C to +60 °C from -20 °C to +70 °C
Material	Stainless steel Q & T steel
Safety requirements	According to ISO 4413:2010 - Hydraulic fluid power — General rules and safety requirements for systems and their components. The system operating pressure must be guaranteed by a safety valve (pressure relief valve).



Dimensions

Cavity

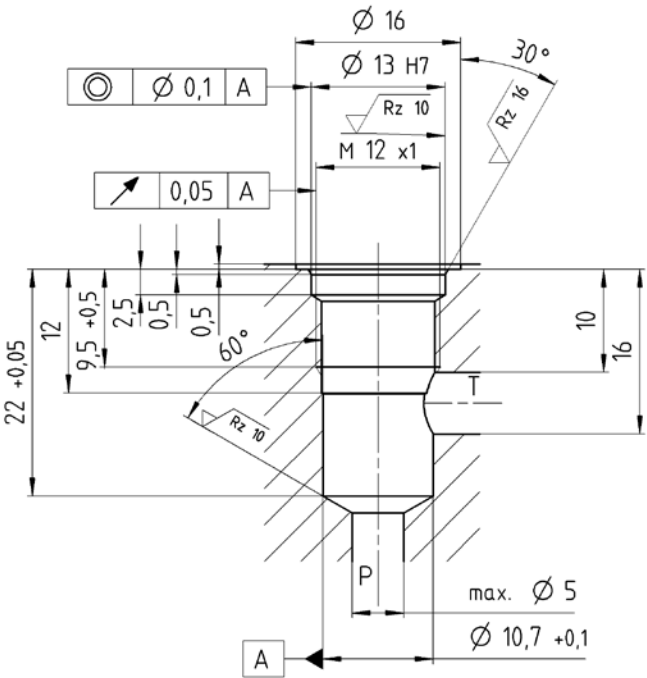

Installation

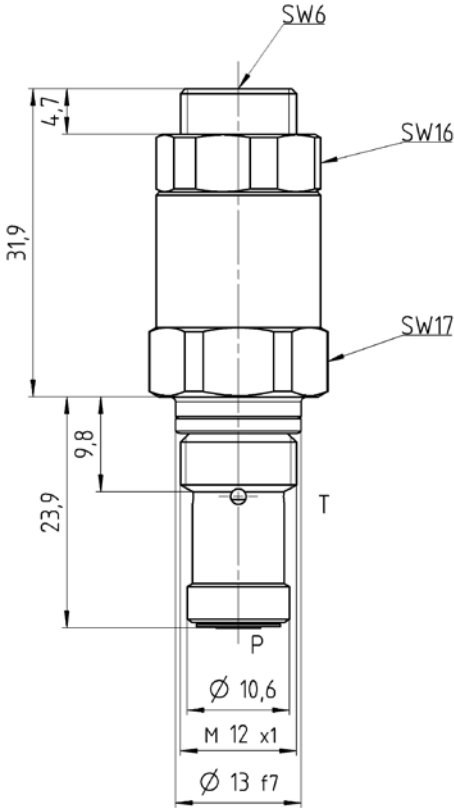

dimensions in mm

Seals	9,25x1,78 NBR 90 Shore A
Cartridge tightening	SW 17, 10 Nm
Pressure adjustment	SW 16. Tighten clockwise to increase pressure

EXTRAORDINARY
PERFORMANCE

EXTRAORDINARY
PERFORMANCE

EXTRAORDINARY
PERFORMANCE



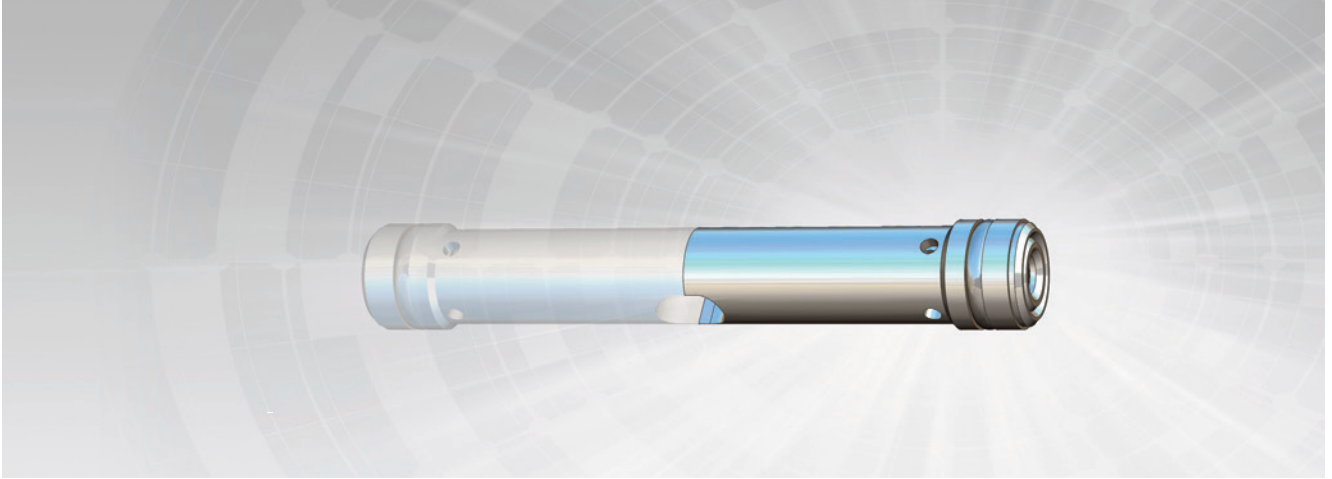

2-way flow control valves MSR are high-performance, load-compensated slip-in cartridges. The flow rate is kept constant independently of the load by means of a fixed orifice. Load compensation takes place by means of a pressure compensator piston that keeps constant the pressure drops across the fixed orifice.

Main features

- Extremely small dimensions
- Max operating **pressure 160 bar**
- Max flow rate **5 l/min**
- Controlled **flow range** from **0,10 l/min** up to **1,55 l/min**
- Very **constant flowrate** (absolute -5 to +10 cm³/min)
- Damping disc
- Minimal tolerances of the restrictor (+0,01 mm)
- Hardened and fitted control piston
- Any installation position
- Manufactured in **small, medium or large batches**

Hydraulic Symbol

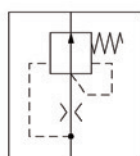

Order Code

1 2 3
 MSR / -

1 Version	
MSR	2-way flow control valve

3 Seals	
N	NBR seals (Standard)
V	FPM seals

2 Flow adjustment (l/min)			
P	0,10 l/min	X	0,60 l/min
S	0,12 l/min	E	0,62 l/min
T	0,15 l/min	J	0,63 l/min
R	0,20 l/min	H	0,65 l/min
U	0,30 l/min	K	0,70 l/min
A	0,31 l/min	L	0,73 l/min
I	0,36 l/min	F	0,77 l/min
W	0,38 l/min	N	0,80 l/min
B	0,40 l/min	G	1,00 l/min
C	0,48 l/min	O	1,20 l/min
V	0,50 l/min	Q	1,330 l/min
D	0,53 l/min	M	1,550 l/min

Ordering example

2-way flow control valve, 0,15 l/min flow adjustment, NBR seals.

MSR/T-N

Technical data

Hydraulic oil: type	HLP 32 (according to DIN 51524-2) filtered 10 µm
contamination degree	ISO 4406:2021 class 18/16/13
Temperatures: operating (fluid)	from +10 °C to +80 °C
ambient, during operation	from -10 °C to +60 °C
transport and storage	from -20 °C to +70 °C
Material	high strength special steel
Safety requirements	According to ISO 4413:2010 - Hydraulic fluid power — General rules and safety requirements for systems and their components. The system operating pressure must be guaranteed by a safety valve (pressure relief valve).



Dimensions

Cavity

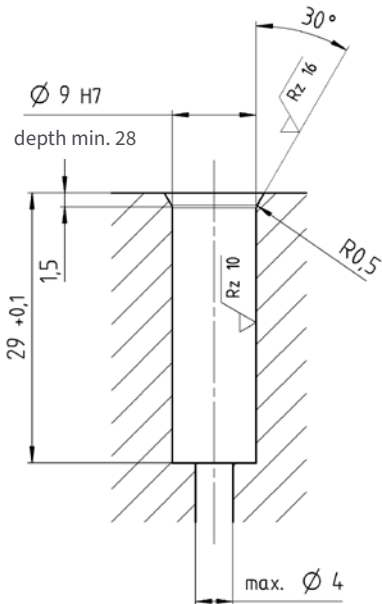

Cartridge

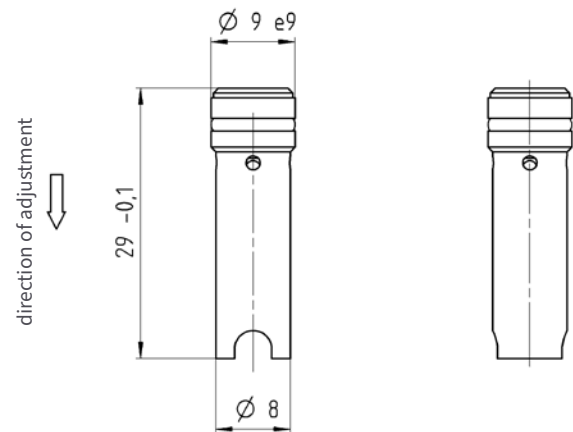

dimensions in mm

Seals	7x1 NBR 70 Shore A
--------------	--------------------

Installation

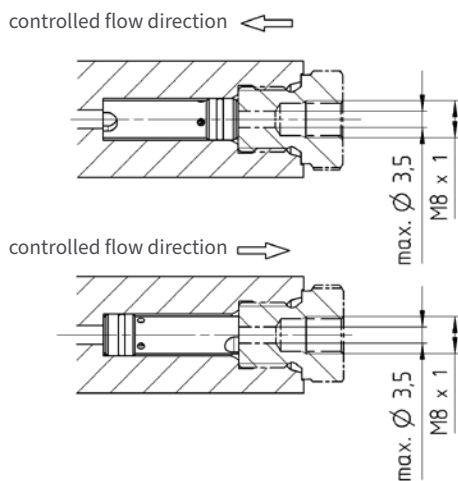

The cartridge can be turned upside down and installed inside the seat depending on the desired direction of the flow.

EXTRAORDINARY PERFORMANCE

SMALL COMPACT SIZE

HIGH FORCE



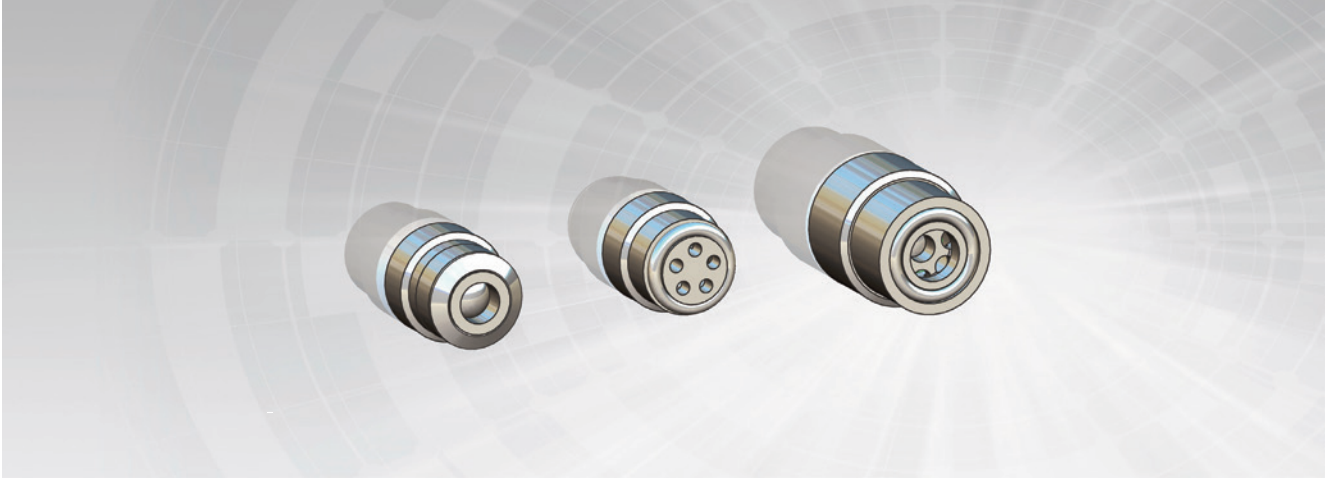

In our micro-hydraulic check valves the hardened ball is guided and pressed onto the sealing seat by means of a spring.

The MPR valves are seal leak-free in or against the screw-in direction, according to the chosen version.

High-quality, coordinated material pairings and durable designed springs ensure a long, leak-free and dynamic service life.

Main features

- Extremely small dimensions
- Absolutely **leak-free**
- Max operating **pressure 160 bar**
- Max **flowrate** MPR1 and MPR2 **5 l/min**; MPR3 **10 l/min**
- Several cracking pressures available
- **Corrosion-resistant** stainless materials and/or coatings
- Simple mounting hole; no special assembly tool required
- Also suitable for pipeline installation
- Manufactured in **small, medium or large batches**

Hydraulic Symbol





Order Code

1 2 3 4 5
 / - -

1 Version	
MPR	Check valves, screw-in

2 Nominal size	
1	M8x1 seat
2	M10x1 seat
3	M14x1,5 seat

3 Cracking pressure (bar)		
MPR1	050	0,50 bar
	060	0,60 bar
	220	2,20 bar
	230	2,30 bar
MPR2	025	0,25 bar
MPR3	013	0,13 bar
	024	0,24 bar
	180	1,80 bar
	250	2,50 bar

4 Free flow direction	
1	from A to B (available only for nominal size 1)
	
2	from B to A
	

5 Seals	
N	NBR seals (Standard)
V	FPM seals

Ordering example

Check valve, M8x1 seat, 2,20 bar cracking pressure, free flow direction from A to B, NBR seals.

MPR1/220-1-N

Technical data

Hydraulic oil: type	HLP 32 (according to DIN 51524-2) filtered 10 µm
contamination degree	ISO 4406:2021 class 18/16/13
Temperatures: operating (fluid)	from +10 °C to +80 °C
ambient, during operation	from -10 °C to +60 °C
transport and storage	from -20 °C to +70 °C
Materials: ball	rolling bearing steel, manufactured according to ISO 3290-1 G5
seat	high strength special steel
Safety requirements	According to ISO 4413:2010 - Hydraulic fluid power — General rules and safety requirements for systems and their components. The system operating pressure must be guaranteed by a safety valve (pressure relief valve).



Dimensions

Cavity

MPR1

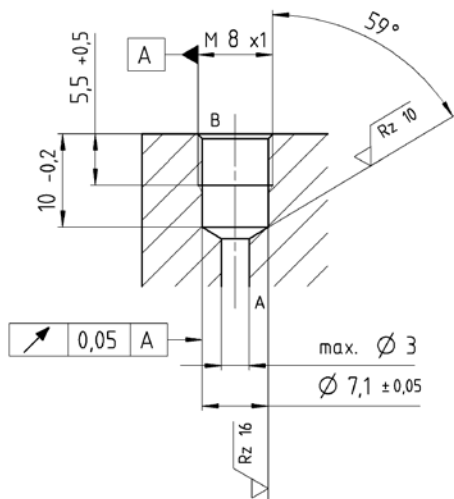

MPR2

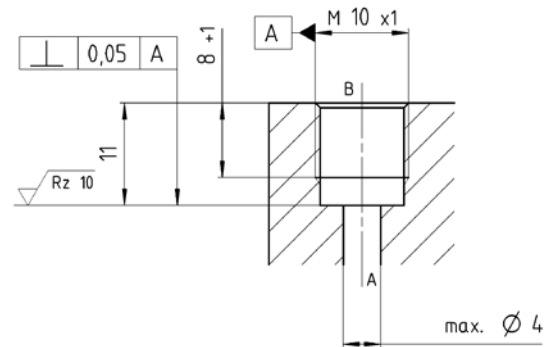

MPR3

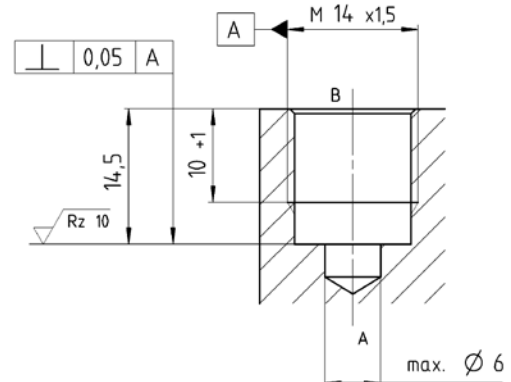

Cartridge

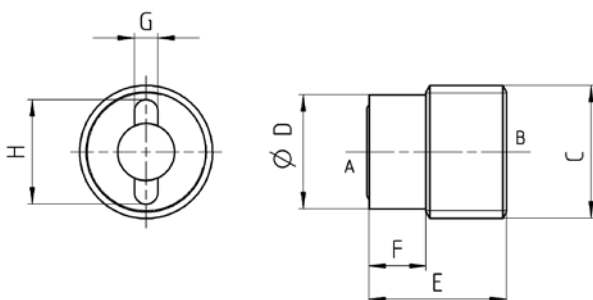

dimensions in mm

Size	Seals	C	ØD	E	F	G	H	Tightening (Nm)
MPR1/**1	4x1 NBR 70 Shore A	M8x1	7	7,45	3,8	2	6	2 + 0,2 Nm
MPR1/**2	4,5x1 NBR 70 Shore A	M8x1	7	7,45	3,8	2	6	2 + 0,2 Nm
MPR2	5x1 NBR 70 Shore A	M10x1	8,6	11	5	2,5	7,7	3 + 0,3 Nm
MPR3	8x1 NBR 70 Shore A	M14x1,5	12	14,5	6	2,5	11	5 + 0,5 Nm



SUBPLATES

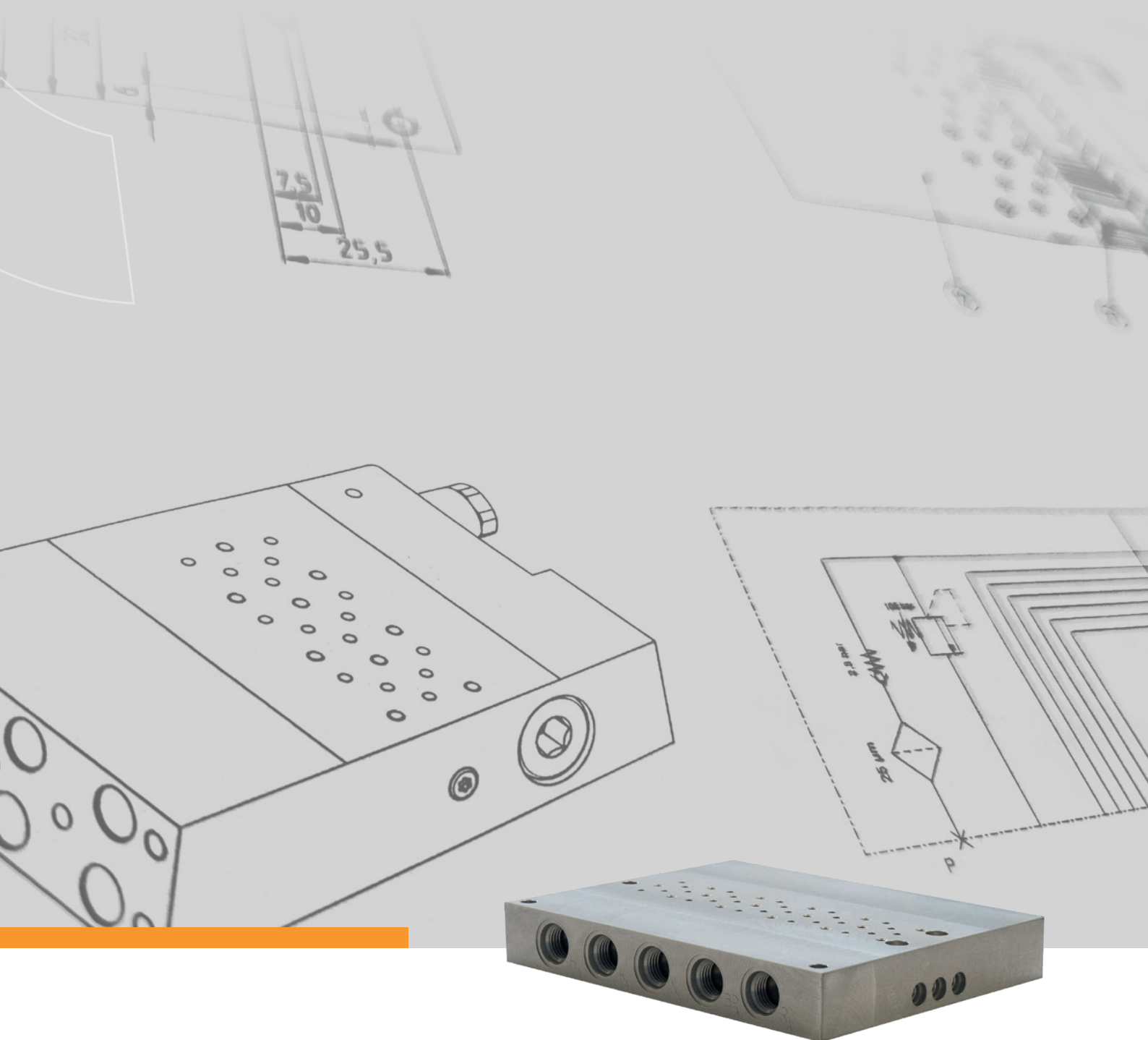

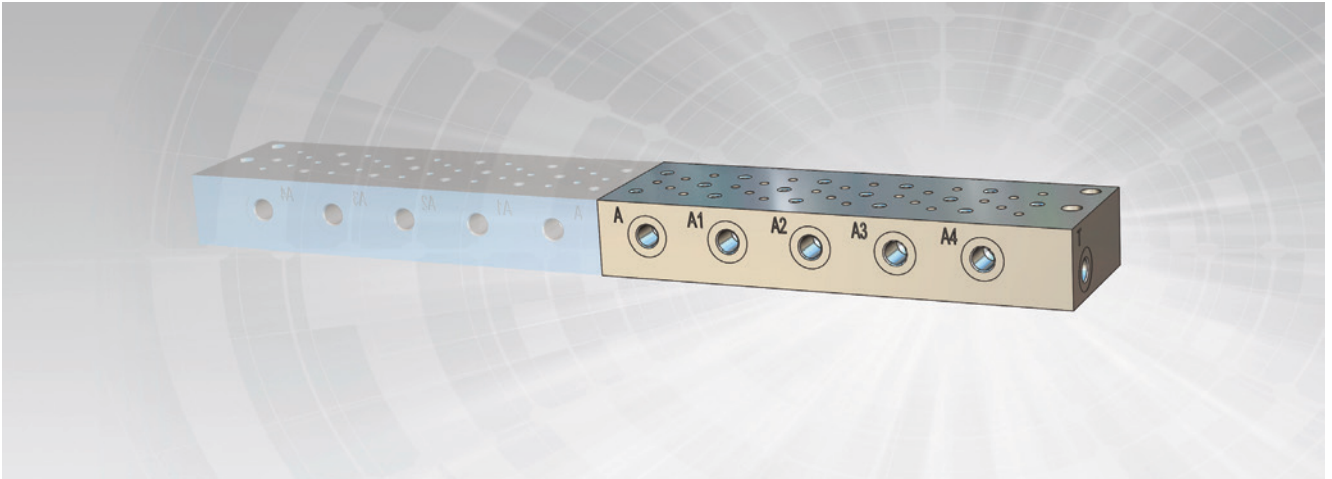

The MGP modular subplates have been designed with one to maximum five stations, to create micro-hydraulic circuits that can be installed in any position. They are available with or without valves technology. The MGP03 series includes a pressure filter, a pressure relief valve and flow control valves.

The station mounting interface fits for our ND3 directional and modular valves such MWV and MRV.

Main features

- Single subplates with 1 to 5 stations
- Max operating **pressure 160 bar**
- Made of **aluminium**, corrosion resistant
- Compact design for small installation spaces
- Any installation position
- Manufactured in **small, medium or large batches**
- **Wide customization** is possible on request

Hydraulic Symbol

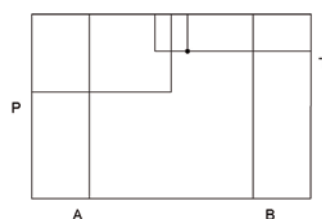

Order Code

1 2 3
 MGP - -

1 Product	
MGP	Micro subplate

2 Versions	
01	Subplate only (without flow control valve)
02	Subplate equipped with flow control valve
03	Subplate equipped with flow control valve, pressure control valve and built-in filter

3 Stations number	
from 01 to 05 stations for MGP-01 and MGP-02	
from 03 to 05 stations for MGP-03	

Versions

MGP-01

Subplate only

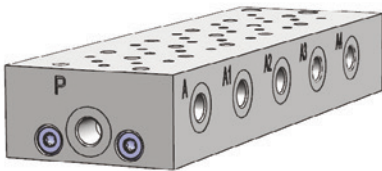

MGP-02

with flow control valve

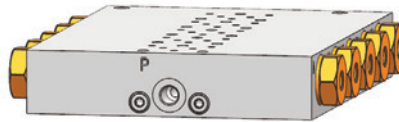

MGP-03

with flow control valve, pressure relief valve and filter

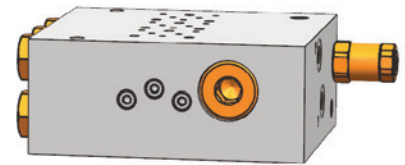

NOTE: Please refer to MSR catalogue for details about the flow control valve.

Technical data

Hydraulic oil: type	HLP 32 (according to DIN 51524-2) filtered 10 µm
contamination degree	ISO 4406:2021 class 18/16/13
Temperatures: operating (fluid)	from +10 °C to +80 °C
ambient, during operation	from -10 °C to +60 °C
transport and storage	from -20 °C to +70 °C
Material	Aluminium
Fixing screws	ISO 4762 M6x35 A 8.8 - Tightening torque 10 Nm
Safety requirements	According to ISO 4413:2010 - Hydraulic fluid power — General rules and safety requirements for systems and their components. The system operating pressure must be guaranteed by a safety valve (pressure relief valve).



MGP-01

Dimensions

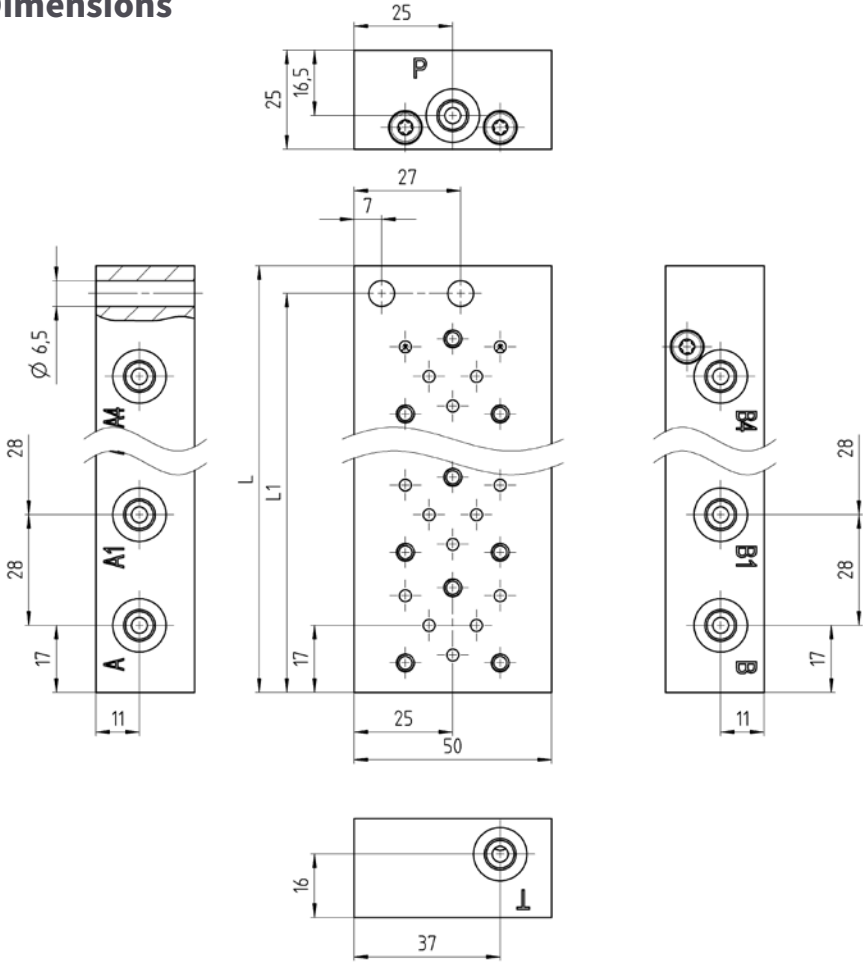

dimensions in mm

Item	L	L1
MGP-01-01	45	38
MGP-01-02	73	66
MGP-01-03	101	94
MGP-01-04	129	122
MGP-01-05	157	150

Ports: M8x1

Hydraulic Symbol

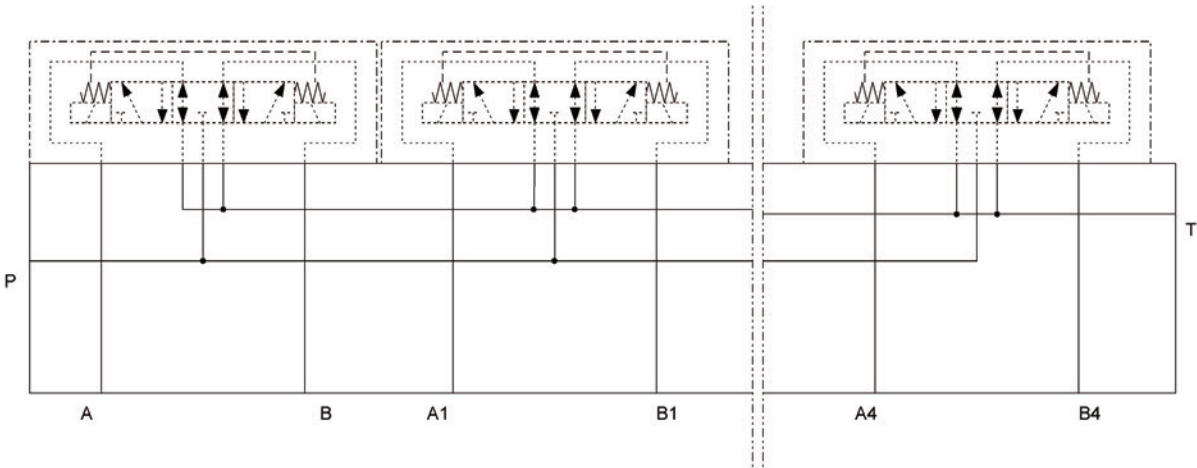

MGP-02

Dimensions

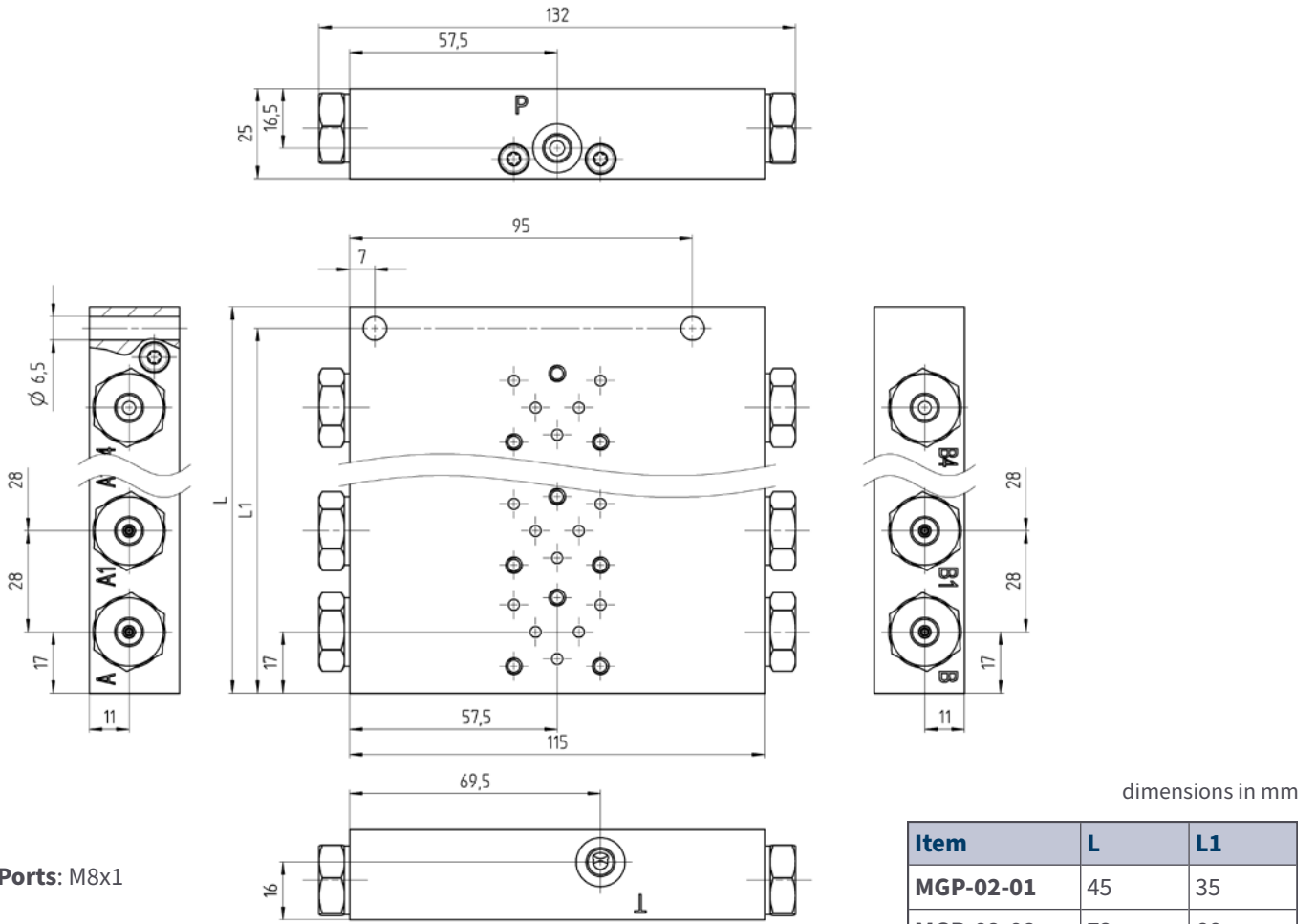

Ports: M8x1

Item	L	L1
MGP-02-01	45	35
MGP-02-02	73	66
MGP-02-03	101	94
MGP-02-04	129	122
MGP-02-05	157	150

Hydraulic Symbol

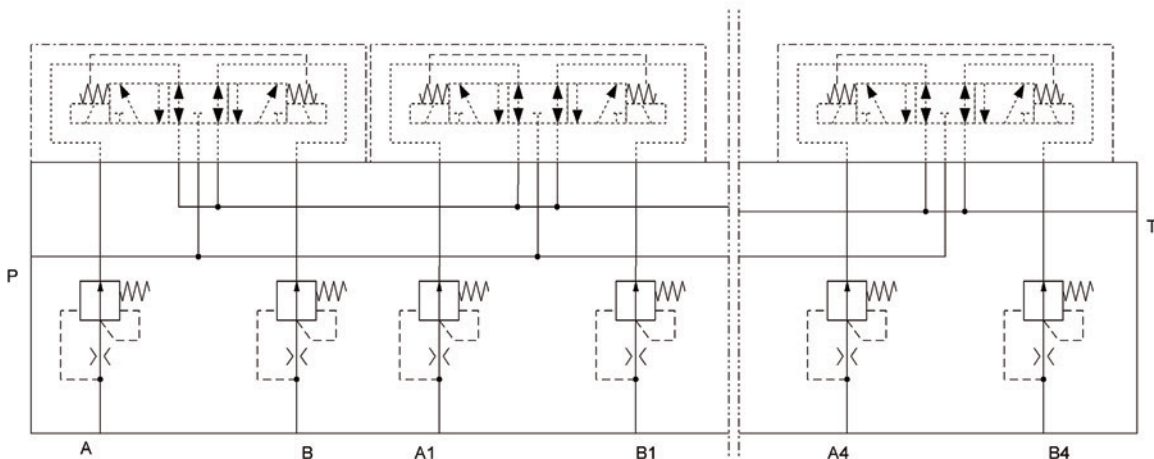

MGP-03

Dimensions

Versions shown in this catalogue are just some of the available versions: the PGM-03 subplate is completely customizable both in terms of size and equipment. contact us for more details.

The three-station subplate is showed here.

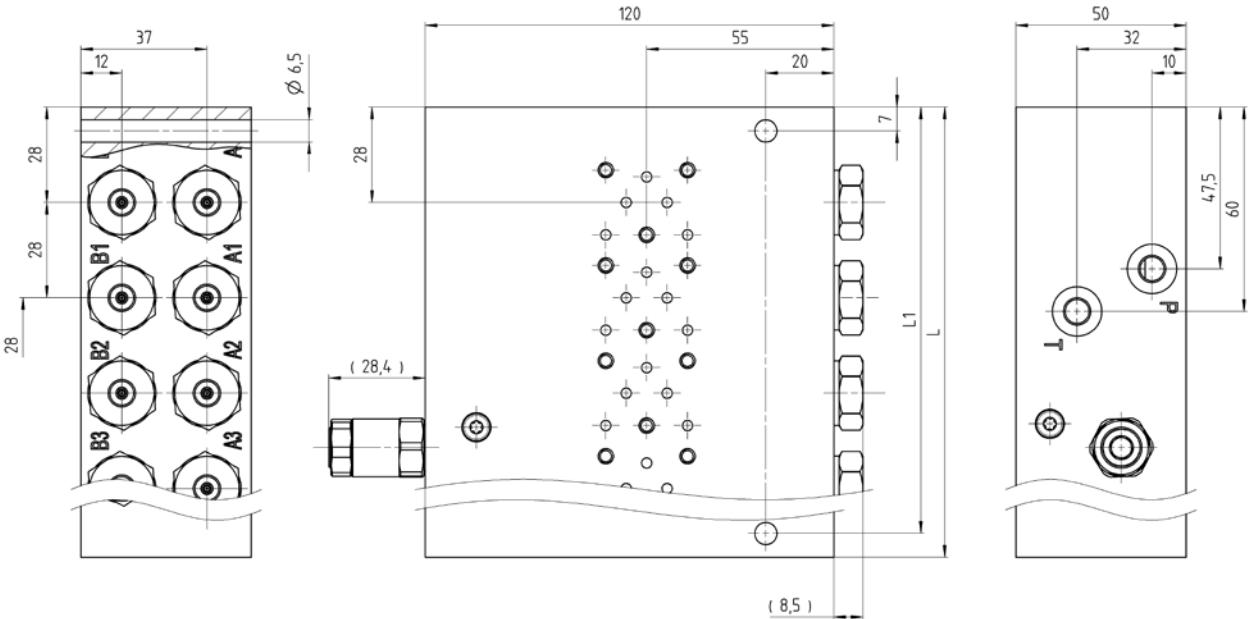

Ports: M8x1

dimensions in mm

Item	L	L1
MGP-03-03	110	103
MGP-03-04	138	131
MGP-03-05	166	159

Hydraulic Symbol

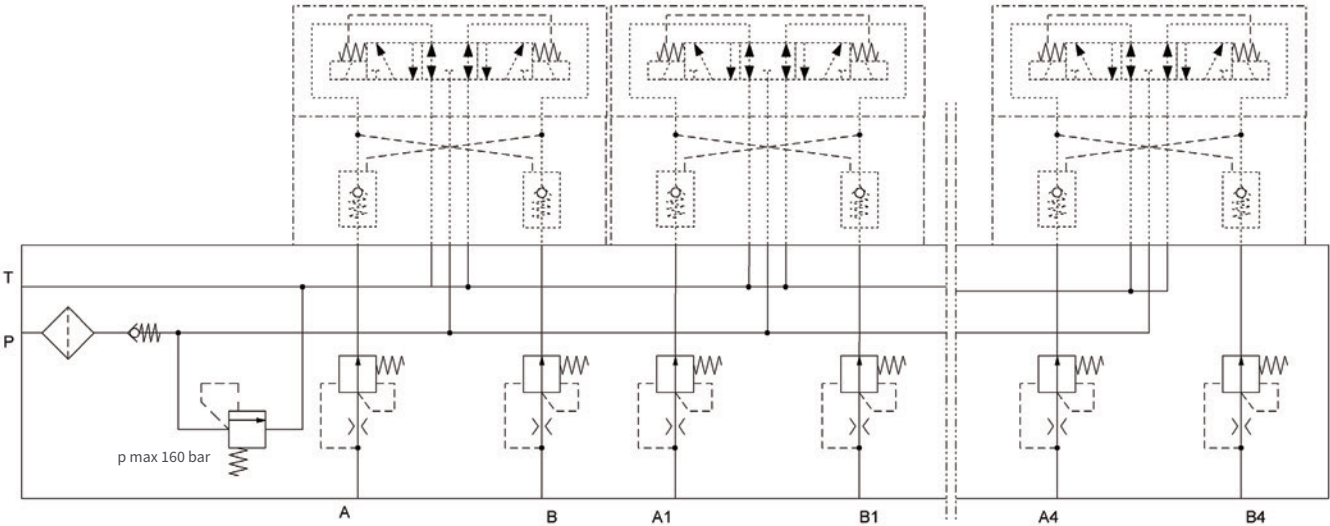



GÜNTER TILL GmbH & Co. KG

Präzisionsmechanik

Mühlgraben 14, D-38350 Helmstedt

Phone +49 (0) 5351 5586 636 | **Fax** +49 (0) 5351 5586 639

Mail mikro@till-hydraulik.de

www.till-hydraulik.de

2023 Edition

