

MS 100
DIRECTIONAL CONTROL VALVE

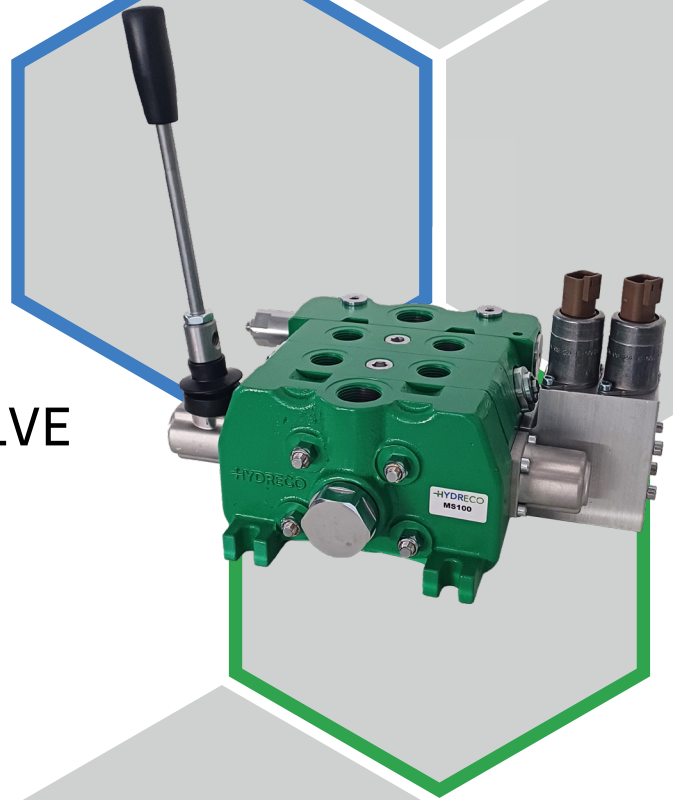

1 INTRODUCTION

The Hydreco MS 100 is a spool directional control valve, the most common type of hydraulic valve in mobile machinery applications, of the "sectional" type to allow greater construction flexibility and maximum customization by the customer.

The Hydreco MS 100 directional valve is of modular construction and consists of:

- An inlet section.
- Up to 10 configurable working sections.
- An outlet section.

The sections are tightly secured by four high-strength steel tie rods, forming a single block.

FEATURES

MS 100 directional control valve has the following:

- cast-iron body (inlet section, working section, outlet section)
- parallel circuit, load check valve protection on each section
- possibility of venting solenoid valve on inlet
- possibility of power beyond configuration
- spool construction in steel, hardened and nickel-plated to achieve higher surface hardness and better corrosion resistance
- several types of spools: double, single acting, motor spool, float position etc.
- interchangeability of all the spools
- possibility of anti-shock and anti-cavitation valves either on port A or B or on both
- several spool control devices and spool positioning devices

VALVES

- pilot operated main relief valve on inlet up to 350 bar - 5000 psi
- solenoid venting valve on inlet: located in the opposite cavity of the main relief valve; available as 12 or 24 Vdc; normally open or normally closed versions
- pilot operated anti-shock and anti-cavitation valve on port A or/and B: set at a higher value (in comparison with the main relief valve), it protects the working ports from load induced pressures, avoids cavitation in the system created by the inertia.

CONTROLS

- handle control
- hydraulic proportional control
- electrohydraulic proportional control

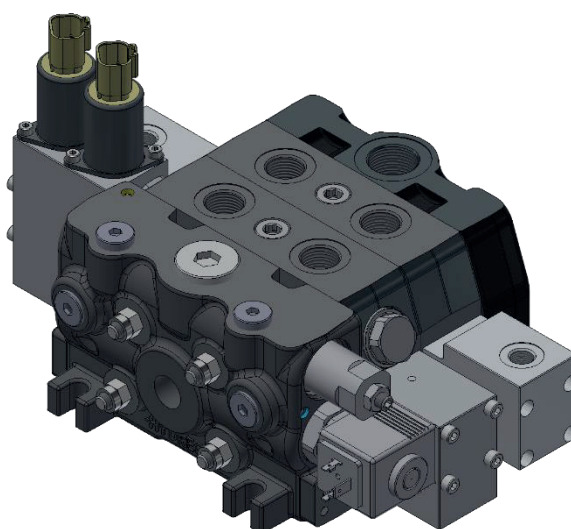

2 TECHNICAL DATA

Spools	from 1 to 10		
Pressures and volumetric flow rate			
Nominal flow rate	Q	100 l/min	26 gpm US
Max pressure	P port	350 bar	5100 psi
	A/B port	350 bar	5100 psi
	T port	30 bar	435 psi
Internal leakage			
at 100 bar (1450 ps)	ports A/B→T	20-30 cm ³ /min	1.217-1.826 cu-in/min
Technical data obtained using mineral oil with 46 cSt			
Spool stroke			
	3 pos. Spools	7 mm	.276 in
	4th pos. extra stroke	5 mm	.197 in

Table 2-1:

3 WORKING CONDITIONS

Hydraulic fluid	mineral oil according to DIN 51524		
Viscosity			
	Range	10...400 mm ² /s	0.15...7.13 in ² /s
	Suggested range	12...75 mm ² /s	0.19...1.16 in ² /s
Temperature			
Fluid temperature range	For NBR (Buna-N):	-20...80 °C	-4...176 °F
	For FPM (Viton):	-20...100 °C	-4...212 °F
	Suggested range	30...60 °C	86...140 °F
Room temperature	Maximum range	-30...60 °C	-22...140 °F
Contamination level			
	Mechanical controls	21/19/16 ISO4406:1999	NAS 1638 class10
	Electro-hydraulic controls	20/18/15 ISO 4406:1999	NAS 1638 class 9

Table 3-1:

For different conditions, please contact the sales department.

4 PERFORMANCE DATA AND METERING CURVES

4.1 PERFORMANCE DATA

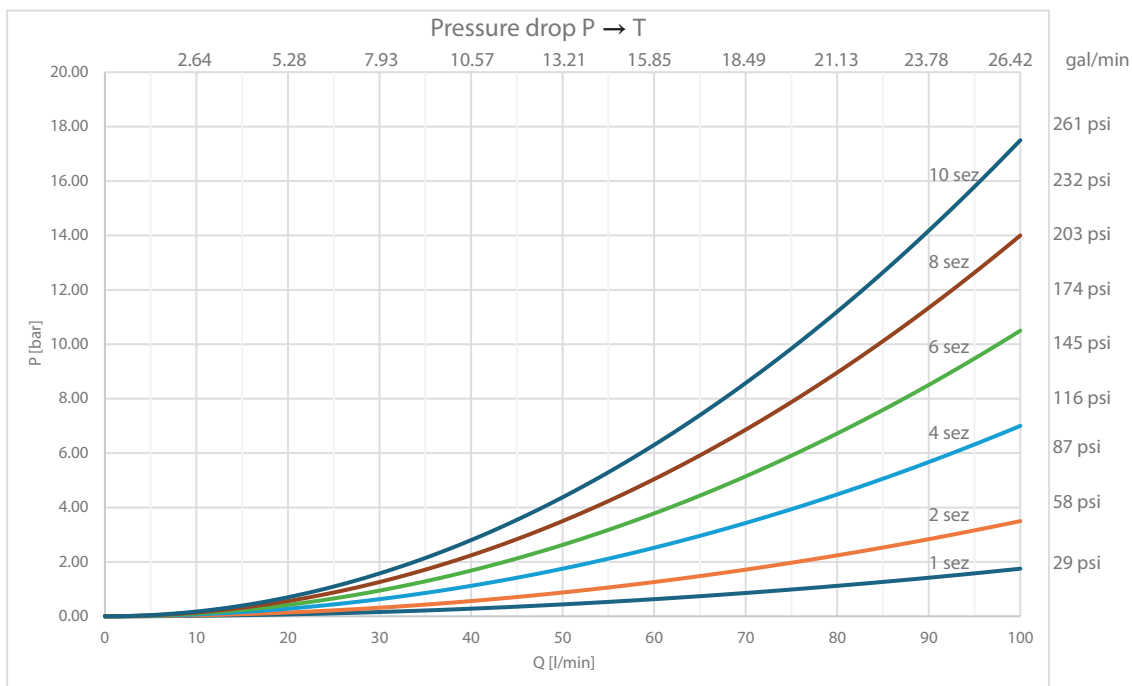

Figure 4-1: Pressure drop P → T

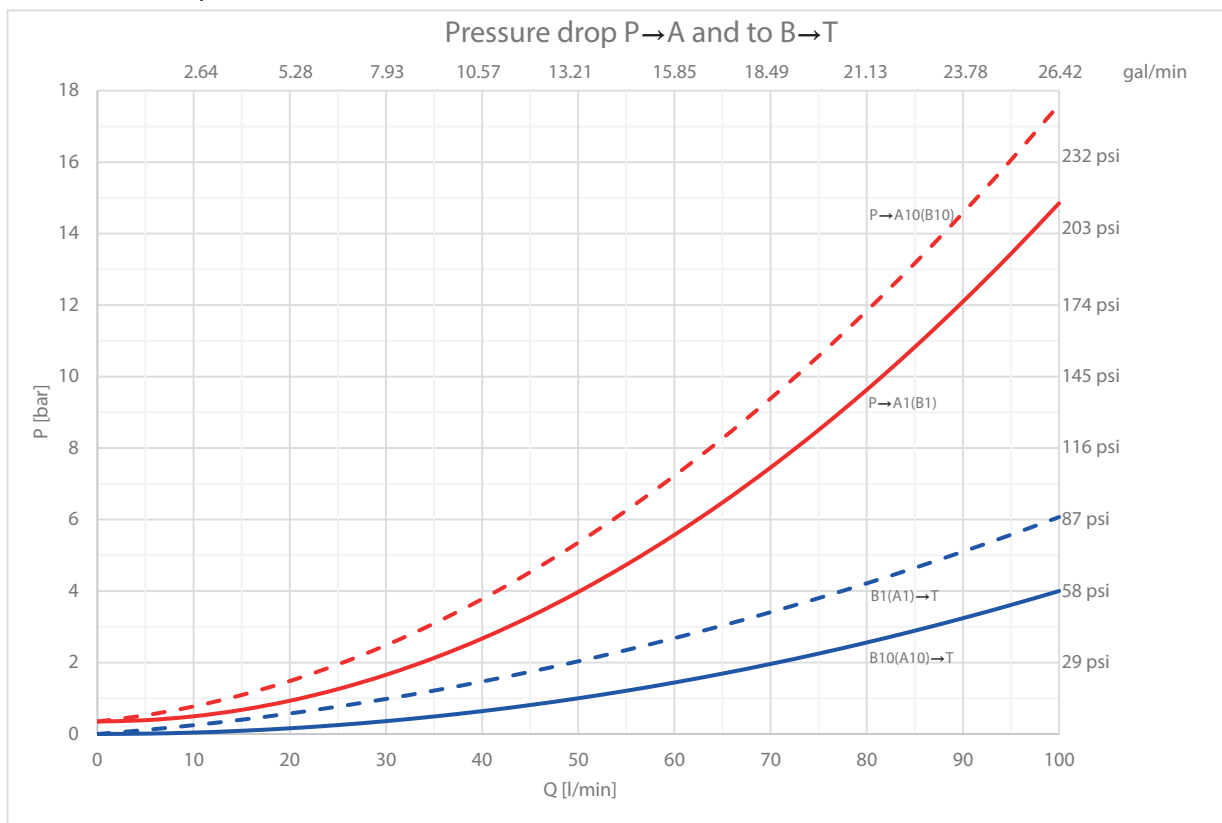

Figure 4-2: Pressure drop P→A and to B→T

The graph shown in the Figure 4-2 is obtained with a standard symmetrical double-acting spool. The load balance between the two ways can be revised according to the customer's requirements to achieve better behavior on the machine/application for which the directional control valve is intended.

4.2 METERING CURVES

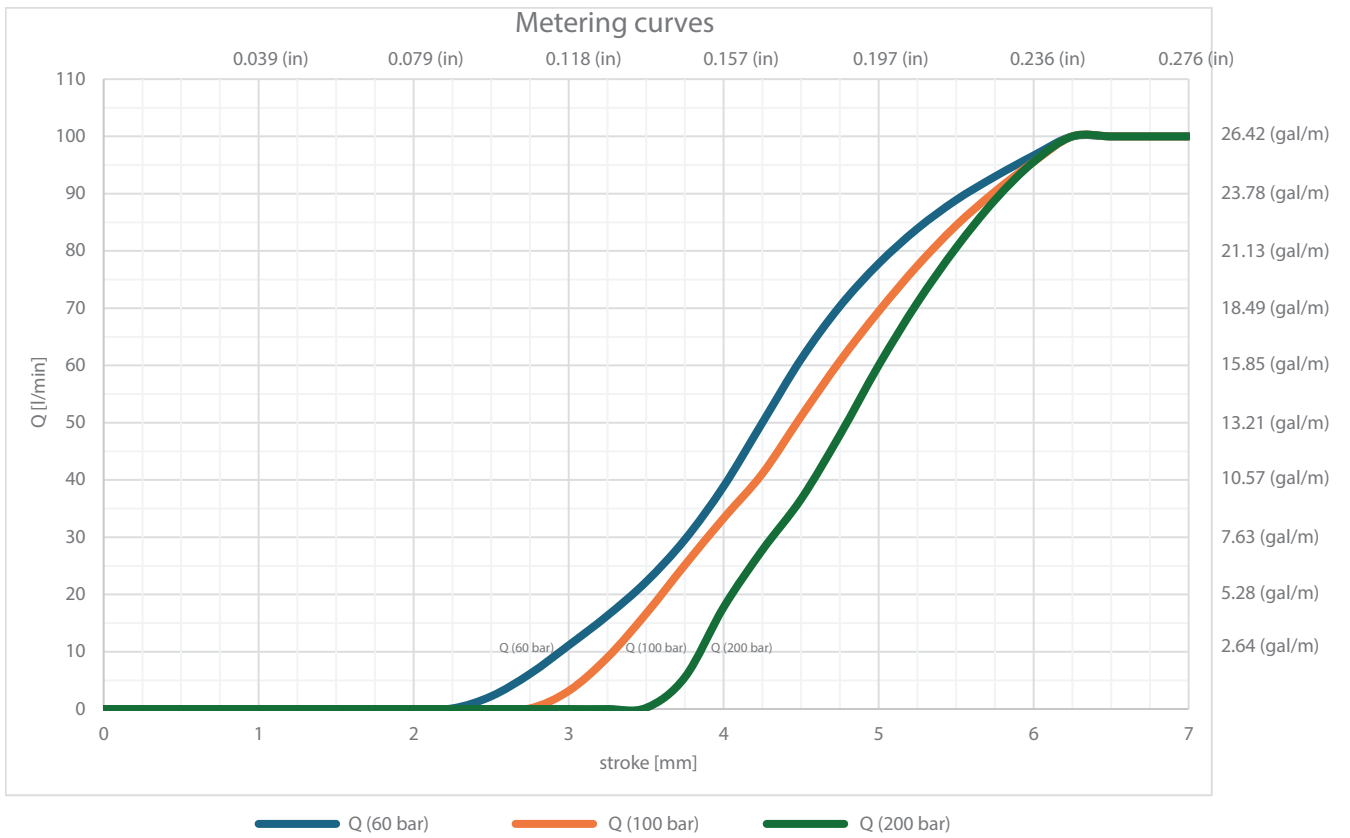

Figure 4-3: Metering curves

5 DIMENSIONS

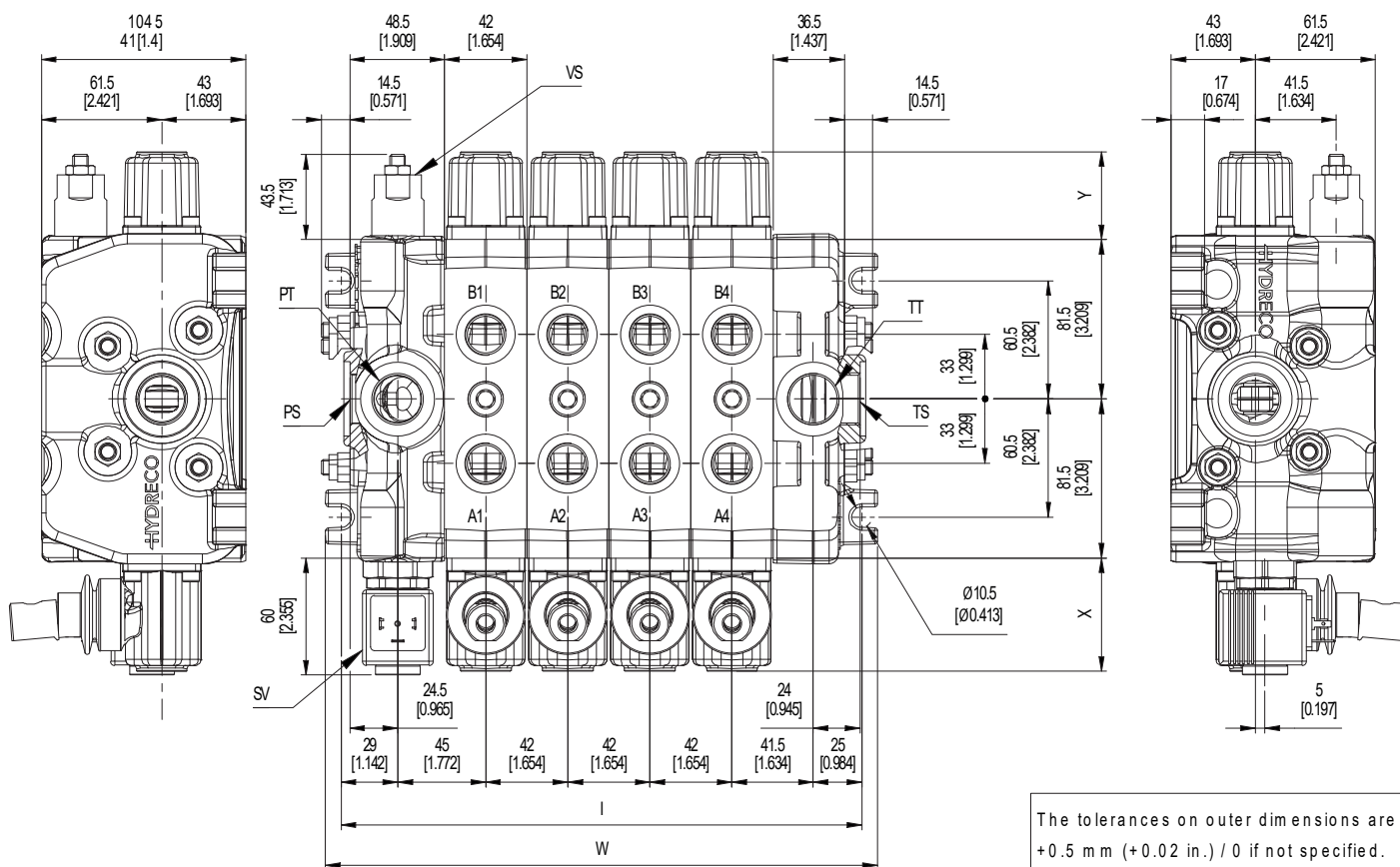

Figure 5-1: MS 100 Directional Control Valve general dimensions

N. of sections	I	W
1	140.5	156.5
2	182.5	198.5
3	224.5	240.5
4	266.5	282.5
5	308.5	324.5
6	350.5	366.5
7	392.5	408.5
8	434.5	450.5
9	476.5	492.5
10	518.5	534.5

INDEX:
 PT = top inlet port
 PS = side inlet port
 TT = top outlet port
 TS = side outlet port
 A/B = working ports
 VS = adjustable main relief valve
 SV = solenoid venting valve (optional).

Table 5-1: General dimensions

6 PORTS

PORT SIZES	PT / PS	A / B	TT / TS	Carry over	piloting / gauge ports	model coding
ISO 1179-1	G 3/4 BSP	G 1/2 BSP	G 3/4 BSP	G 1/2 BSP	G 1/4 BSP	1
JIS B 2351-90	G 3/4	G 1/2	G 3/4	G 1/2	G 1/4	2
ISO 9974-1	M27 x 2	M22 x 1.5	M27 x 2	M22 x 1.5	M14 x 1.5	3
ISO 6149-1	M27 x 2	M22 x 1.5	M27 x 2	M22 x 1.5	M14 x 1.5	4
ISO 11926-1	1 1/16-12 UN-2B (SAE 12)	7/8-14 UNF-2B (SAE 10)	1 1/16-12 UN-2B (SAE 12)	7/8-14 UNF-2B (SAE 10)	9/16-18 UNF-2B (SAE 6)	5

Figure 6-1: Port sizes

The standard port sizes are **GAS threads according to ISO 1179-1**. Upon agreement with our sales office, it is possible to request the fittings listed in the Table 6-1.

When ordering, specify at the end of the "how to order" description which type of port you prefer, indicating with a number from 1 to 5 corresponding to the required standard, starting from top to bottom (i.e., 1 corresponds to ISO 1179-1).

7 INLET MODULES

7.1 INLET MODULES FOR MECHANICAL AND HYDRAULIC CONTROLS HM

7.1.1 DIMENSIONS

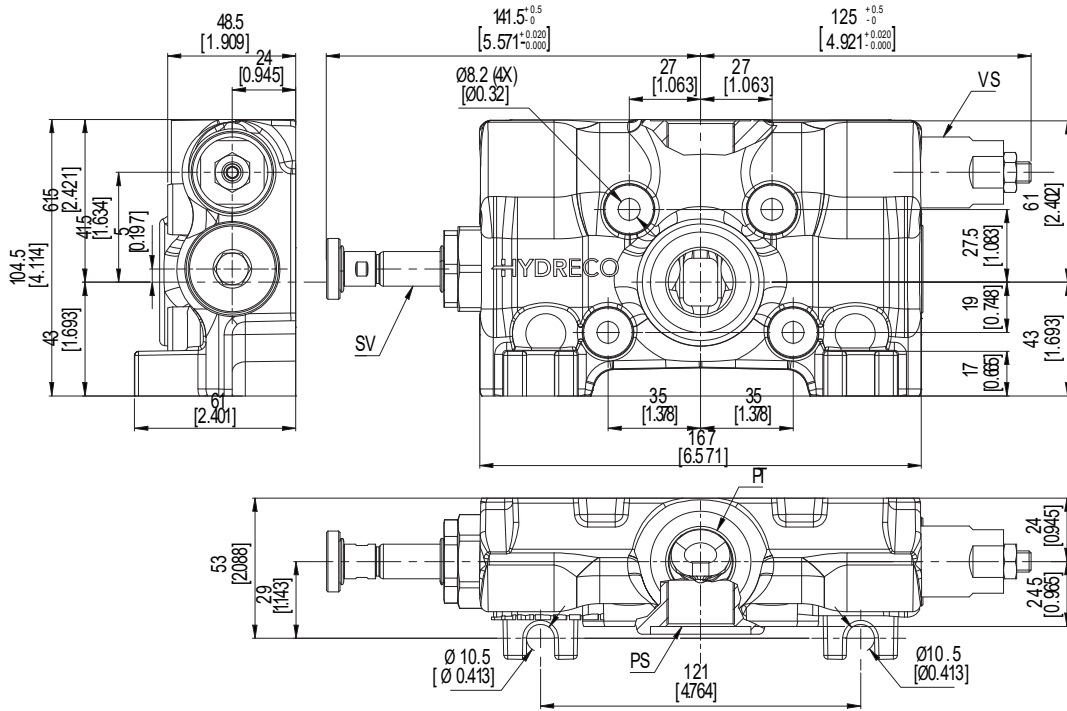

Figure 7-1: Dimensions of inlet modules for mechanical and hydraulic controls HM

7.1.2 HYDRAULICS DIAGRAMS

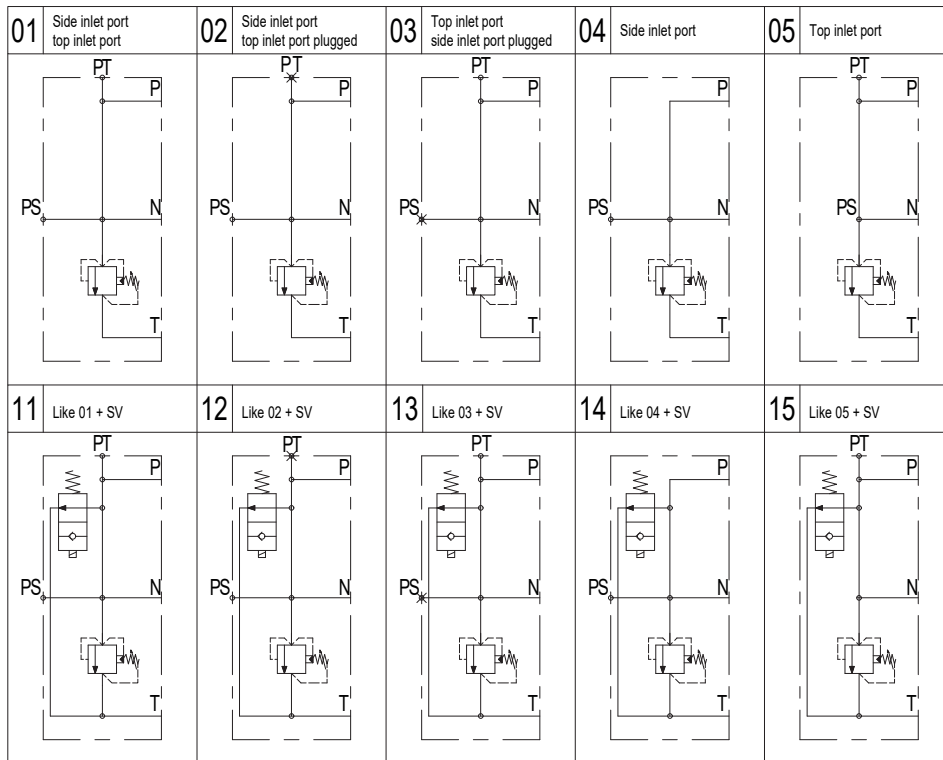

Figure 7-2: Hydraulic diagrams available for inlet modules for HM controls

7.2 INLET MODULES FOR ELECTRO-HYDRAULIC CONTROLS EH

7.2.1 DIMENSIONS

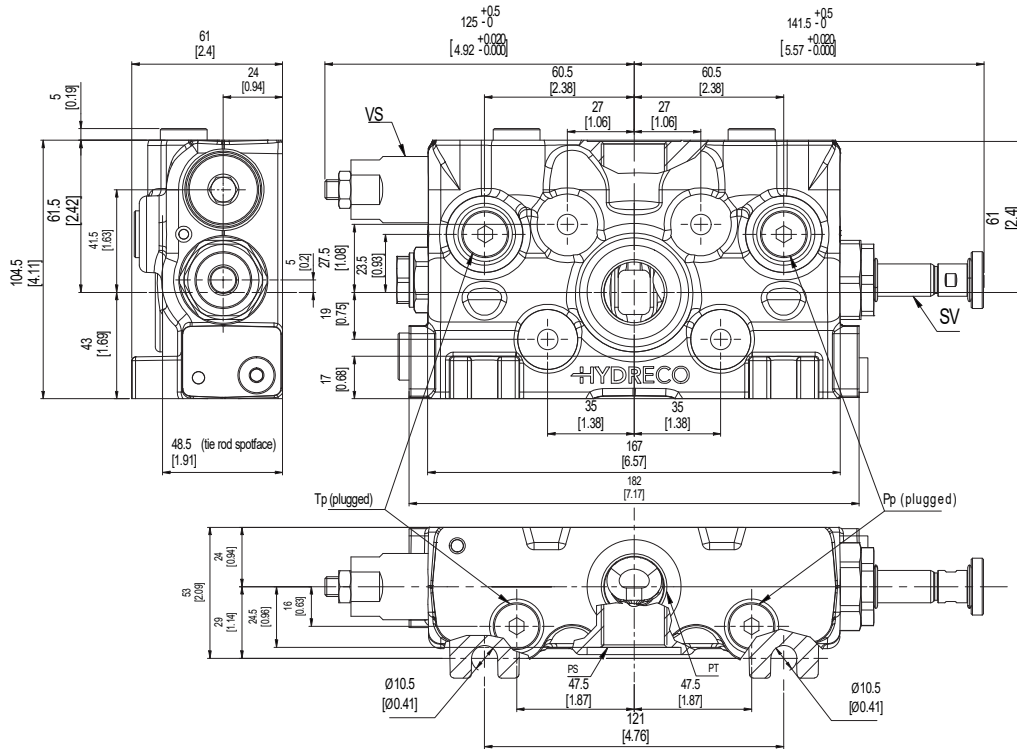

Figure 7-3: Dimensions of inlet modules for electro-hydraulic controls EH

7.2.2 HYDRAULICS DIAGRAMS

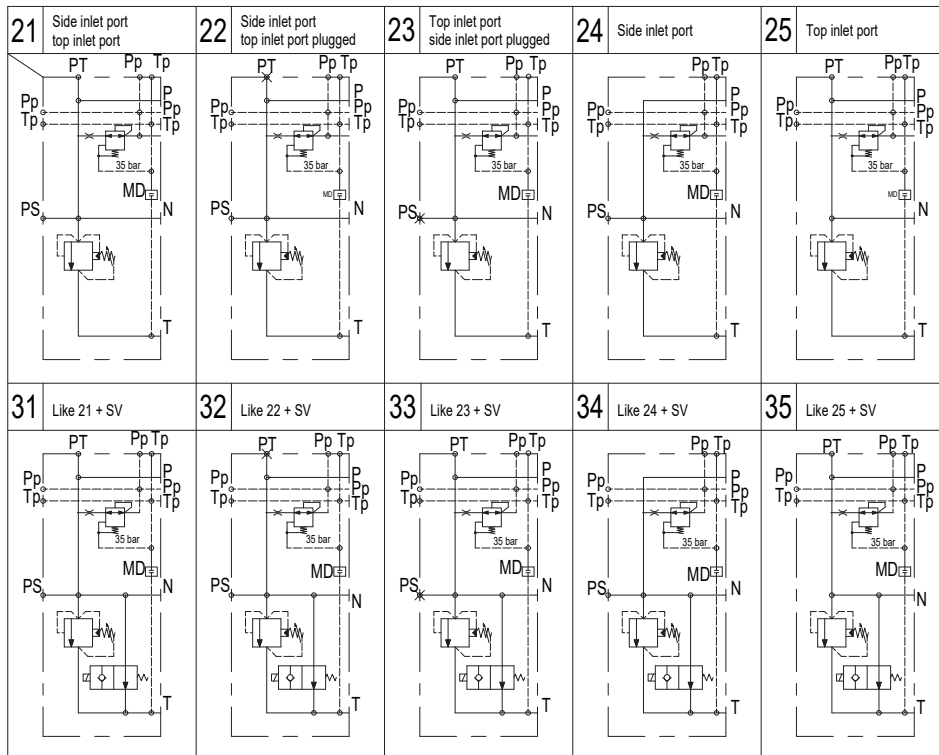

Figure 7-4: Hydraulic diagrams available for inlet modules for electro-hydraulic controls EH

8 WORKING SECTIONS

8.1 DIMENSIONS FOR MECHANICAL AND HYDRAULIC CONTROLS HM

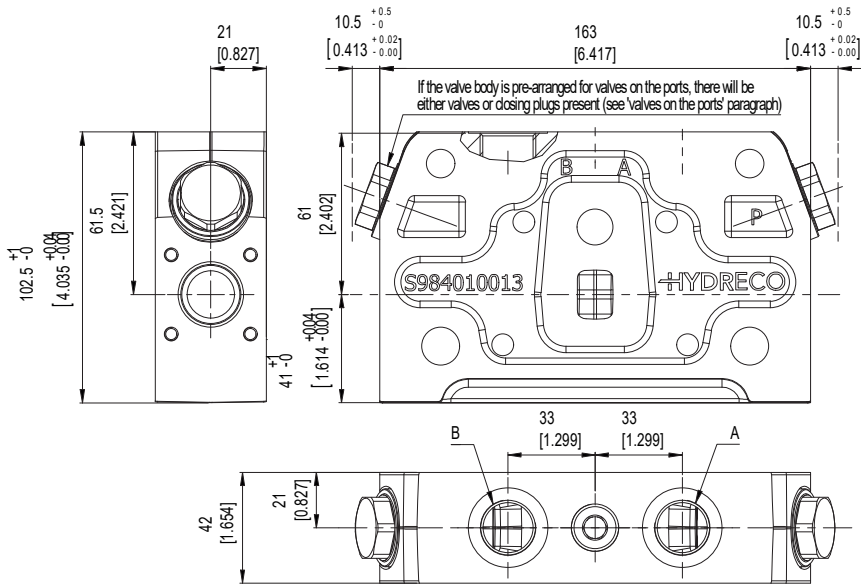

Figure 8-1: Dimensions of working section for mechanical an hydraulic controls HM

8.2 DIMENSIONS FOR ELECTRO-HYDRAULIC CONTROLS EH

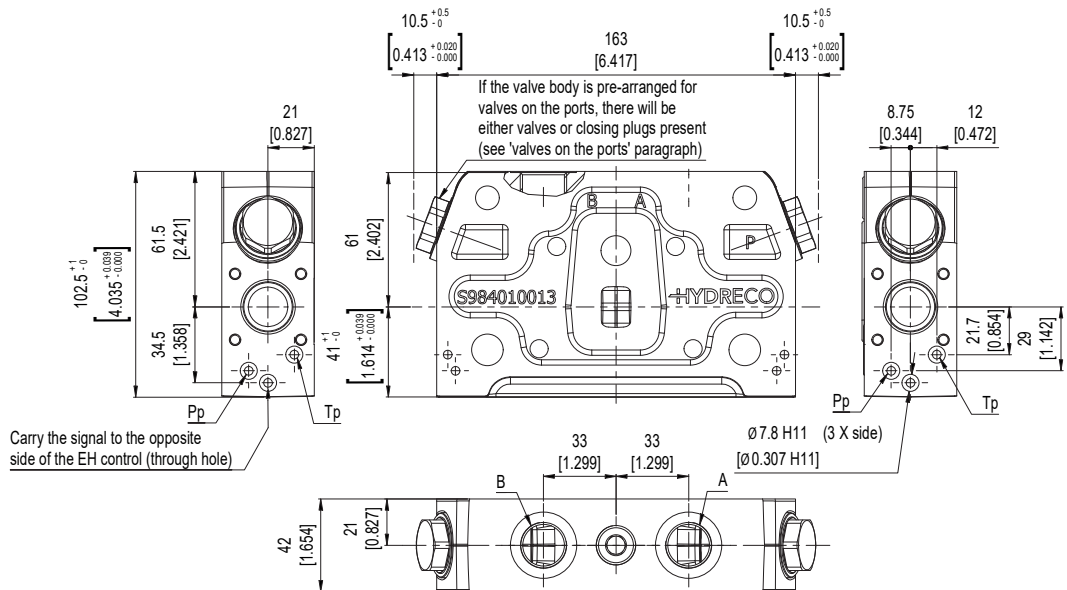

Figure 8-2: Dimensions of working section for electro-hydraulic controls EH

8.3 HYDRAULIC DIAGRAMS

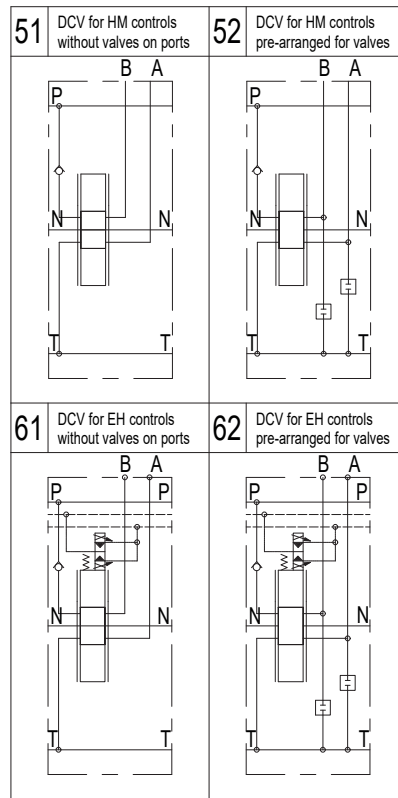
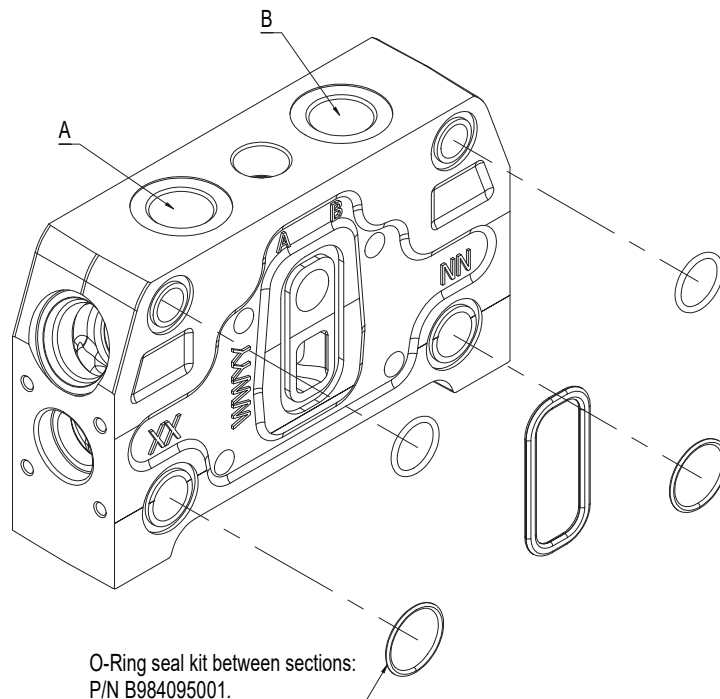

Figure 8-3: Hydraulic diagrams available for working sections

8.4 O-RING SEAL KIT



9 OUTLET MODULES

9.1 DIMENSIONS

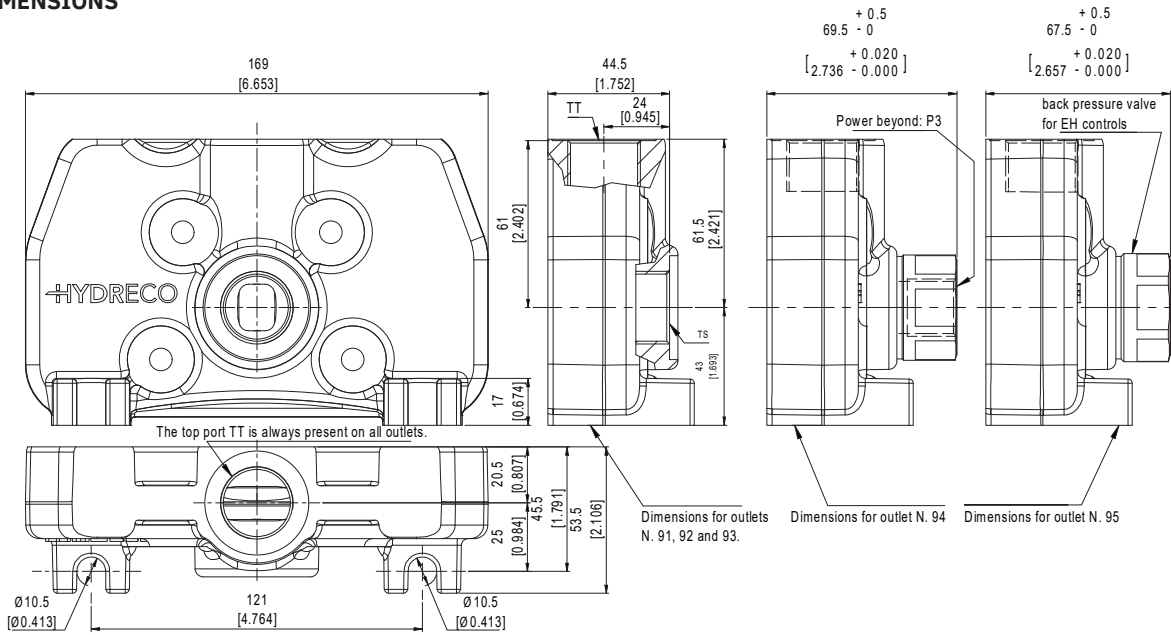

Figure 9-1: Dimensions of outlet modules

9.2 HYDRAULICS DIAGRAMS

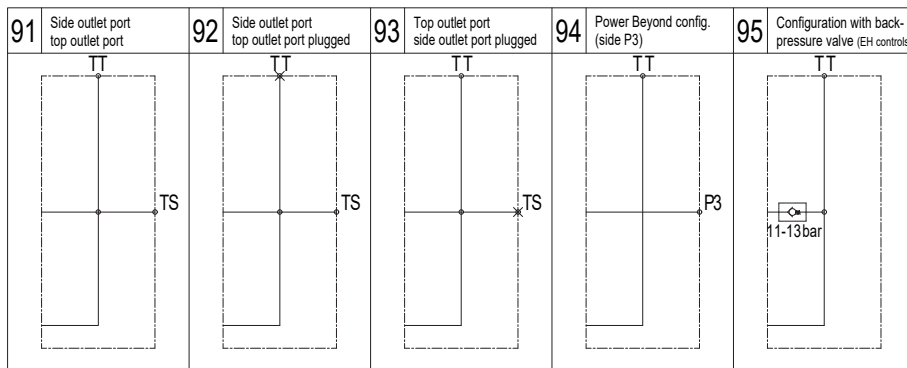
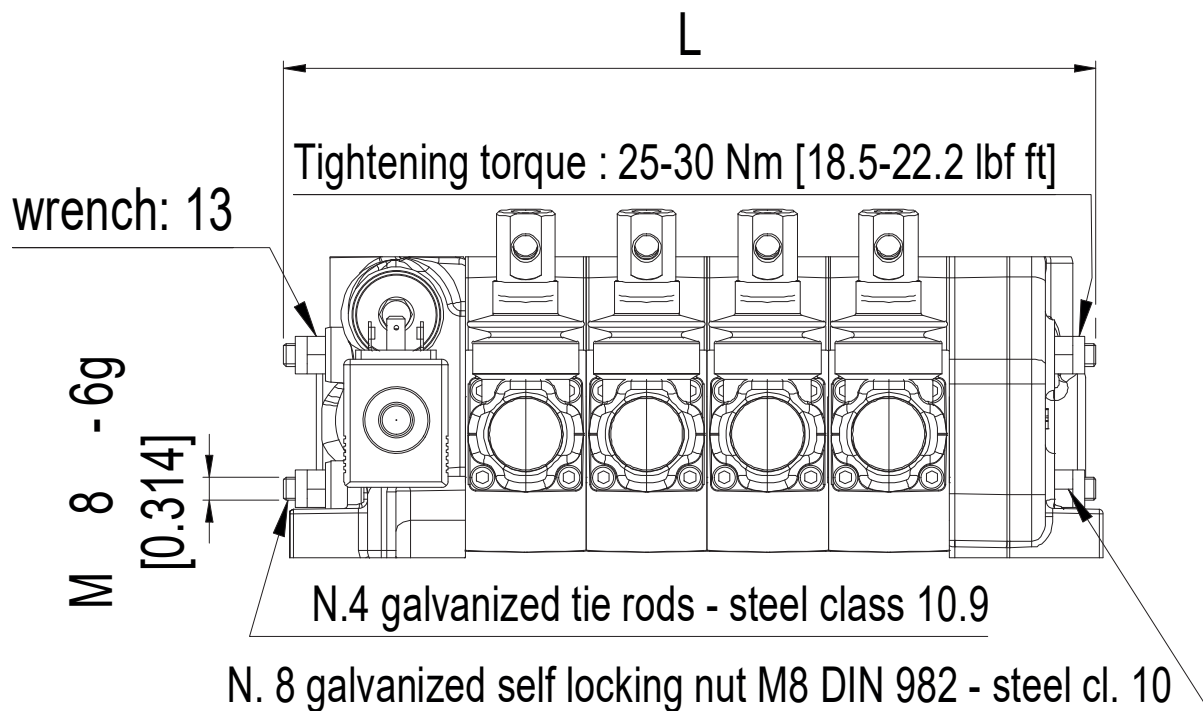

Figure 9-2: Hydraulic diagrams available for outlet sections

10 ASSEMBLING TIE-RODS



N. of sections	L [mm]
1	156
2	198
3	240
4	282
5	324
6	366
7	408
8	450
9	492
10	534

Figure 10-1: Lengths of tie rods as a function of the number of working sections

11 SPOOL TYPES

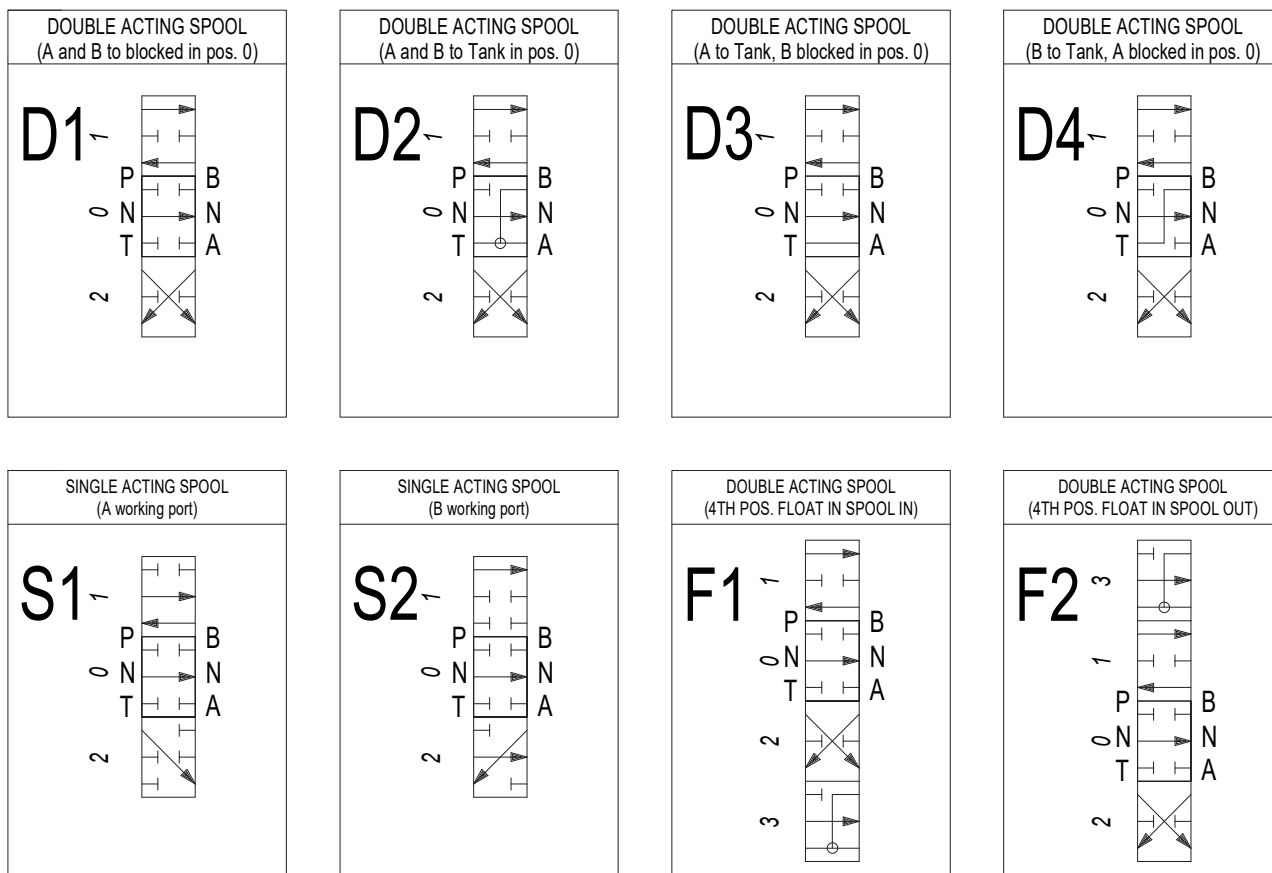
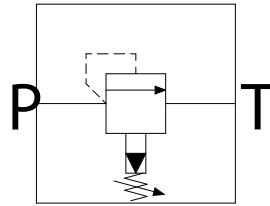

Figure 11-1: Table of Available Hydraulic Functions

After the spool code, when ordering, it is possible to choose if the spool should be:

- For nominal flow rates (option A).
- Restricted, with a reduced flow rate, approximately 2/3 of the nominal flow rate (option R).

12 MAIN RELIEF VALVE VS



The main relief valve is the PRK10 by Duplomatic: a pilot operated valve cartridge valve for 7/8-14 UNF-2B (SAE 10 standard) cavity suitable for pressures up to 350 bar and flow rates up to 120 l/min. However, due to its particularly "flat" characteristic, which will be highly appreciated, it could operate at higher flow rates.

The pressure is adjustable via a recessed hex screw with a locknut.

Except for particular cases, such as the venting valve option, where the solenoid coil might interfere with the main relief valve under certain circumstances, the installation of PRK10 is unrestricted, whether on side A or side B, relative to the view facing the side inlet port PS.

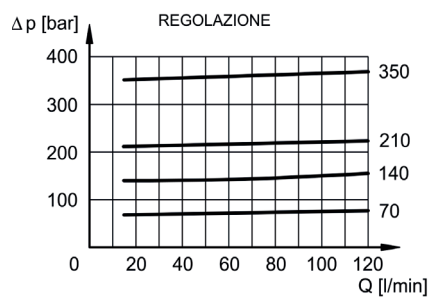
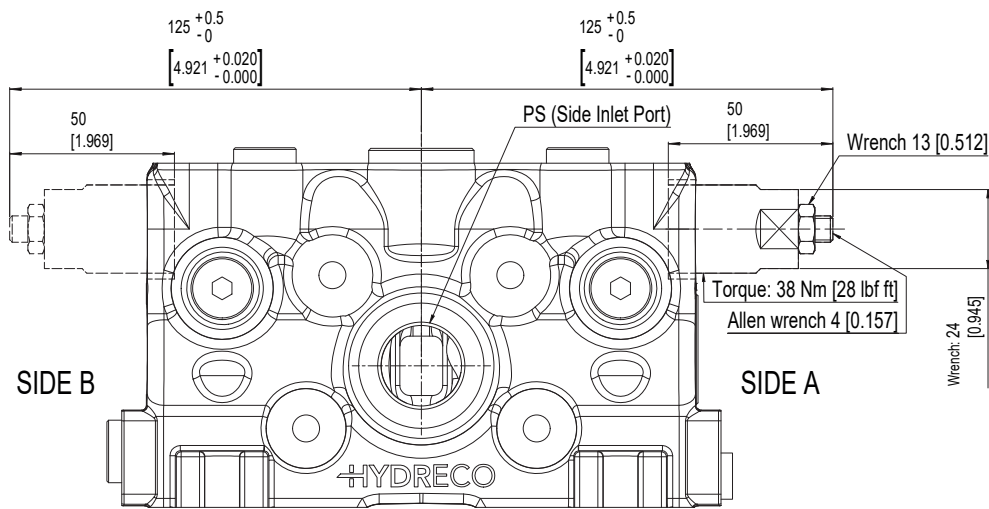

Figure 12-1: Flow-Pressure drop chart

Main Relief valve	setting range	bar/turn
PRK10-070/12N	14-70	17
PRK10-140/12N	70-140	32
PRK10-210/12N	140-210	47
PRK10-350/12N	210-350	78

Figure 12-1: Table of Setting Ranges with bar/turn screw register

The opposite side from where you choose to place the valve will be plugged with a sealed cap that isolates the pressure from the T line.

13 VENTING VALVE SV

Optionally, it is possible to install a solenoid valve with venting function (SV) on the inlet module. The positioning of the valve is unrestricted with HM (hydraulic and mechanical) control inlet modules, whereas with EH control inlet modules, the venting valve can only be positioned on side A. In this case, we recommend installing the main relief valve on the opposite side to have maximum freedom in orienting the solenoid valve coil. Otherwise, the coil can only be oriented if rotated 90° counterclockwise relative to the drawing.

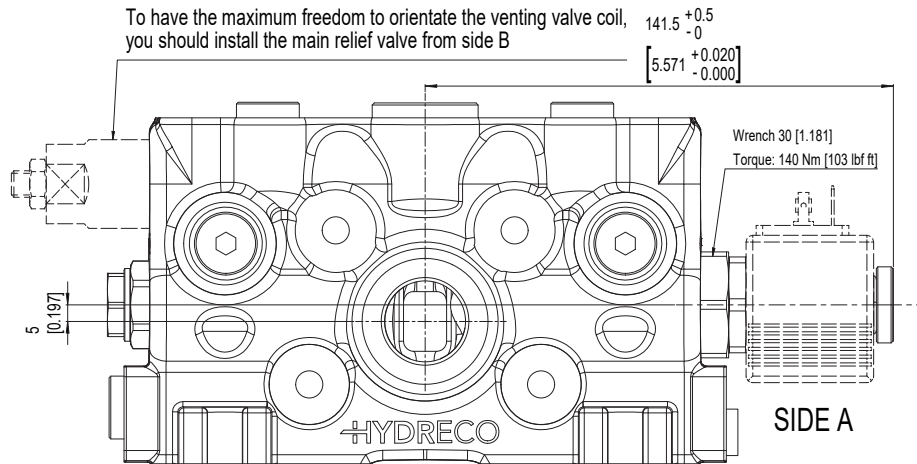

13.1 PERFORMANCE DATA

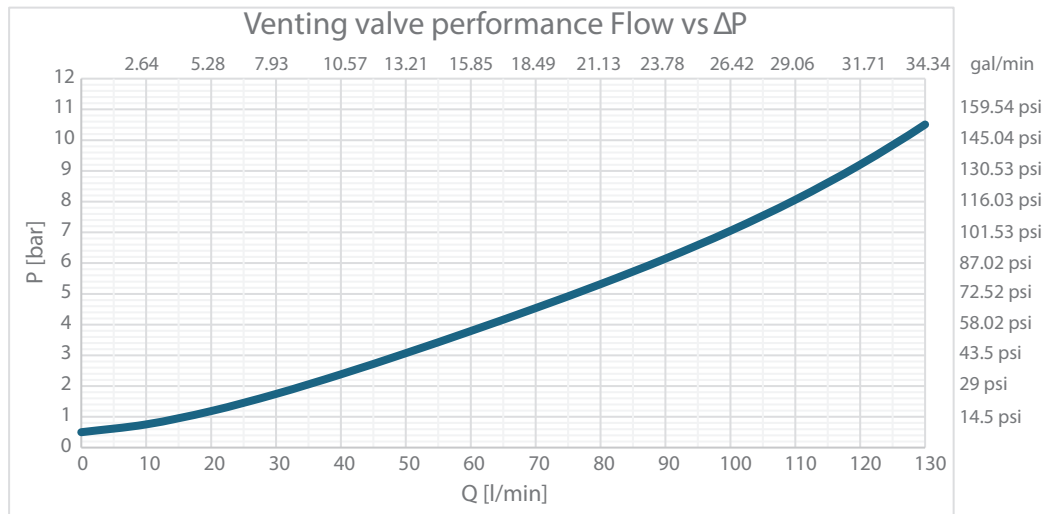

Figure 13-1: Performance data

13.2 VALVE SPECIFICATIONS

Specifications		
Max Pressure	350	bar
Max Flow	130	l/min
Oil Leakage (46 cSt & 350 bar)	1	cm ³ /min
Voltage	12-24	Vdc
Class	IP69	

Figure 13-2: Venting valve specifications

13.3 COILS

They are Class H coils (180°C or 356°F), which ensure 100% duty cycle (ED) up to 85% of Vdc at an ambient temperature of 60°C (140°F).

Voltage	R [Ω]	i [A]	Power [W]
12	9	1.33	16
24	36	0.67	16
Connector:	DEUTSCH-DT04-2P-V		

Figure 13-3: Coil specifications

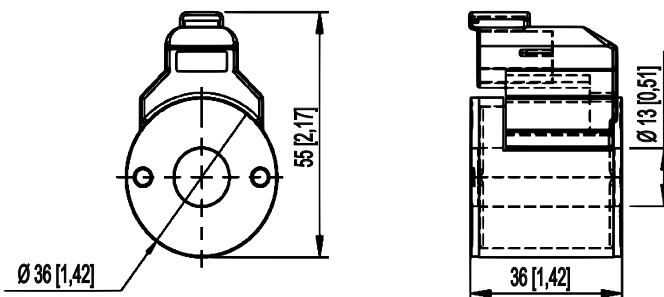

Figure 13-3: Coil dimensions

Protection rating: IP 69

13.4 COMMERCIAL CODES

Voltage	Normally open	Normally close
12V	SV1	SV2
24V	SV3	SV4
No SV	SV0	

Table 13-4: Commercial codes for venting valve SV

14 AUXILIARY VALVES

In the working sections pre-arranged for valves on the ports, it is possible to add pressure control valves.

14.1 ANTISHOCK RELIEF AND ANTI CAVITATION VALVE AS

The anti-shock and anti-cavitation valve protects the cylinder from overloads caused by impacts or the inertia of the mass, and simultaneously, helps to fill oil back into the cylinder volume when a sudden movement would lead to cavitation.

The valve can be installed on side A, on side B, or on both sides.

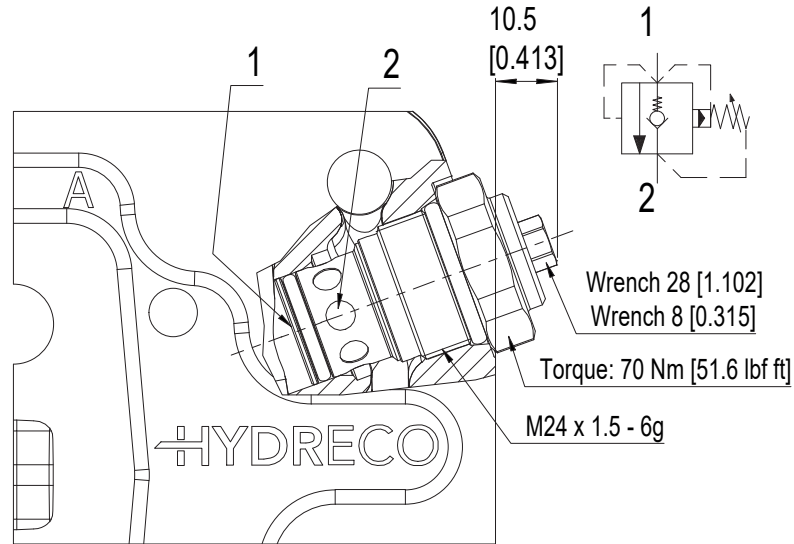

Pressures and volumetric flow rate	
Max pressure	420 bar
Max. flow rate	130 l/min
Leakage at 100 bar (46 cSt)	
Max. Internal leakage	1 cm ³ /min

Table 14-1: Valve data

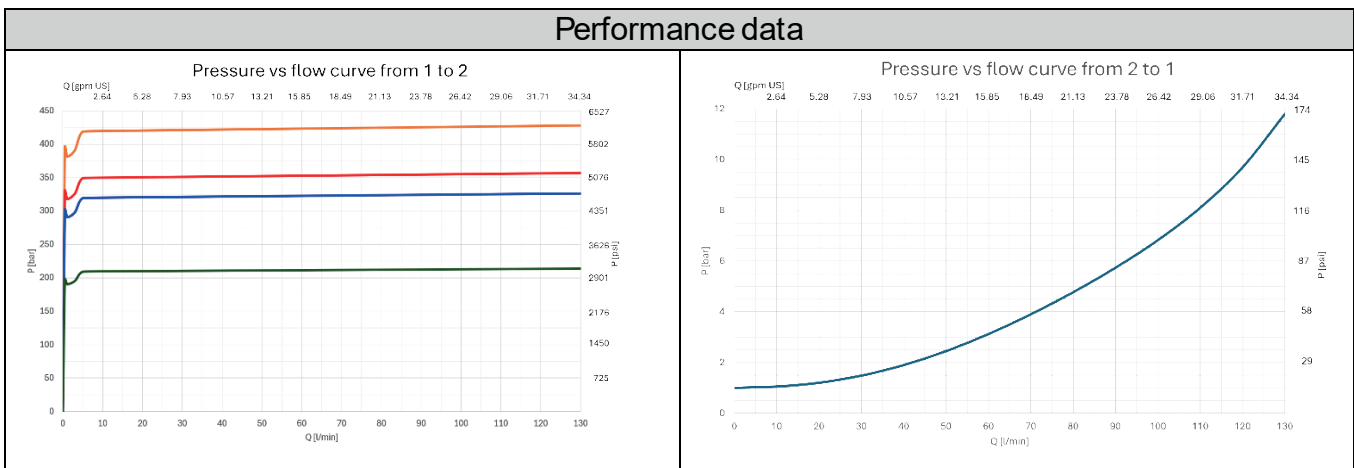
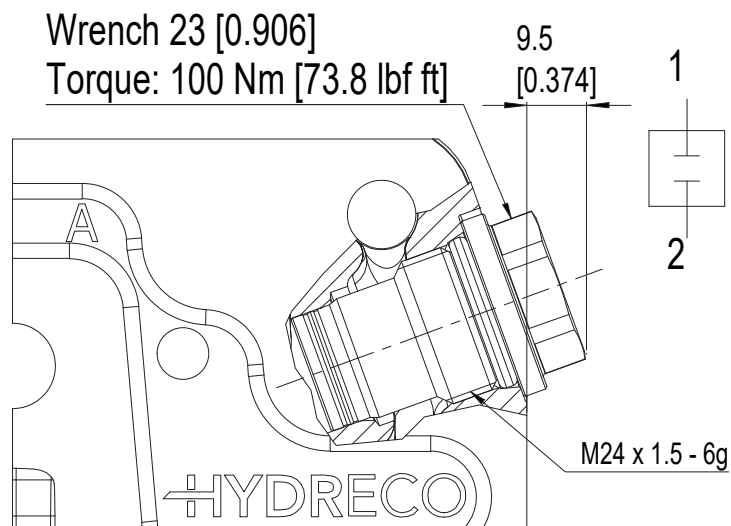

Table 14-2: Valve performance data

14.2 PLUG FOR CAVITY AP

If you do not want to install the valve but would like to plan for its future use, choose a working section pre-arranged for valves on the ports and configure it with this sealed plug that isolates the work port from the T-Line.



14.3 COMMERCIAL CODES

When ordering, you will need to specify the type of valve (AS with setting or AP) followed by the side where it should be mounted and the setting of the valve, e.g., ASA350, APB means an AS valve set at 350 bar on side A and the AP plug on side B of the directional valve.

CODES		DESCRIPTION
ASA XXX	ASB XXX	Anti-Shock Relief and Anti-Cavitation Valve on both sides
ASA XXX	APB	Anti-Shock Relief and Anti-Cavitation Valve side A and Plug in side B
APA	ASB XXX	Plug in side A and Anti-Shock Relief and Anti-Cavitation Valve side B
APA	APB	Plug on both sides
NOP		The cavities are not present in the current working section

15 SPOOL CONTROLS AND SPOOL POSITIONINGS

Normally, we mount the controls and positioners as they appear in the views of this catalog, but:

- All controls can be mounted on side A or side B (this determines the side of the positioner).
- The controls can be rotated 180° relative to the spool axis during ordering.

If you have doubts about how to determine the side of the directional control valve MS 100, see Figure 5 1: side A is the one where you see the working ports named A1, A2, ...

15.1 STANDARD PROTECTED LEVER MP

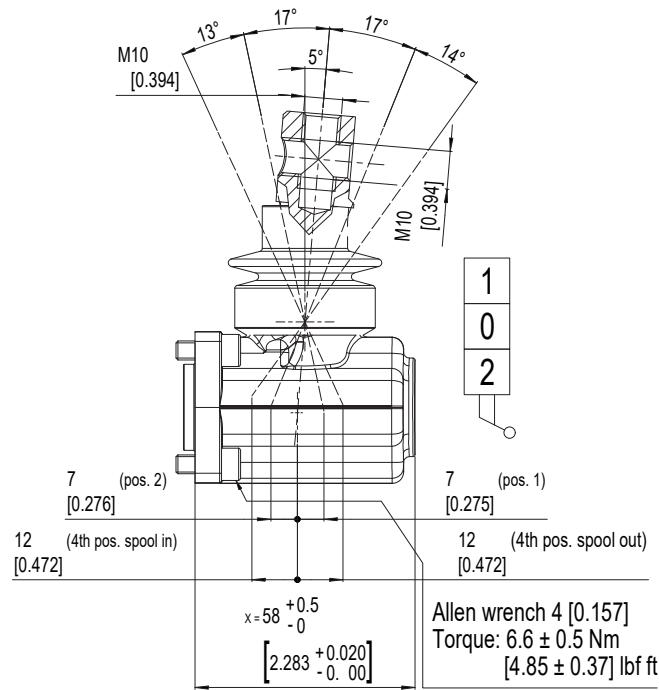

Figure 15-1: Standard protected lever MP

The protected standard lever MP covers the normal positions [1][0][2] but also works with an extra-rotation both in spool in and spool out for spools with the fourth position.

When placing your order, specify MPA or MPB depending on the side where you want the lever to be installed. If you only write MP, the lever will be installed by default on side A.

15.2 HYDRAULIC PROPORTIONAL CONTROLS HP

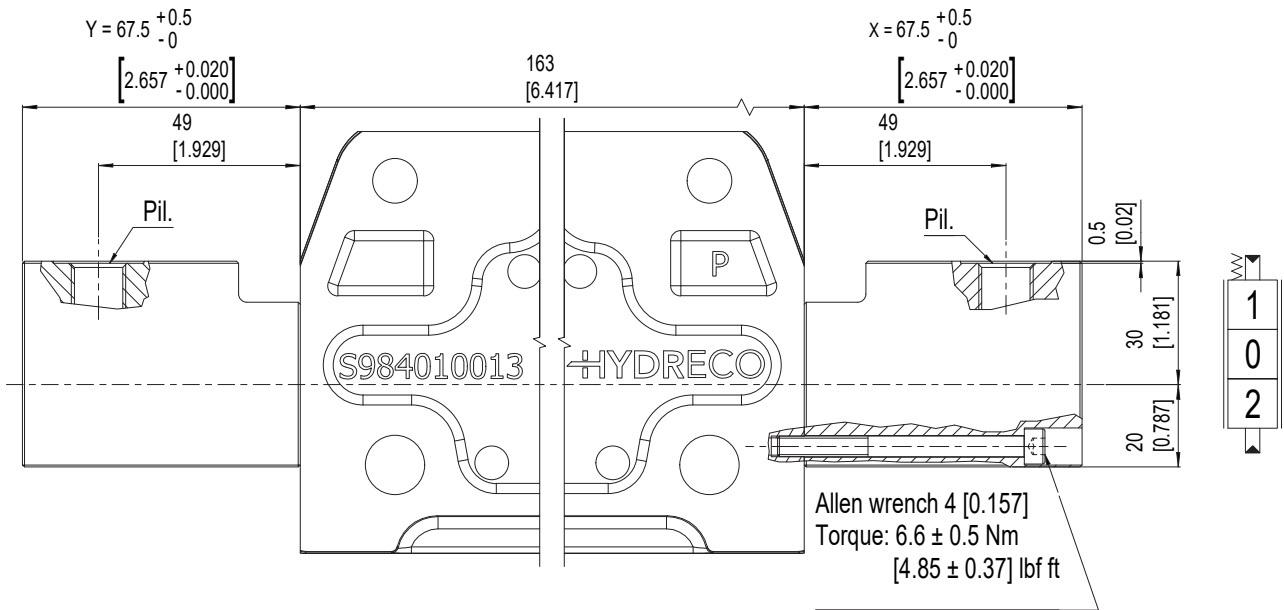

Figure 15-2: Hydraulic proportional controls HP

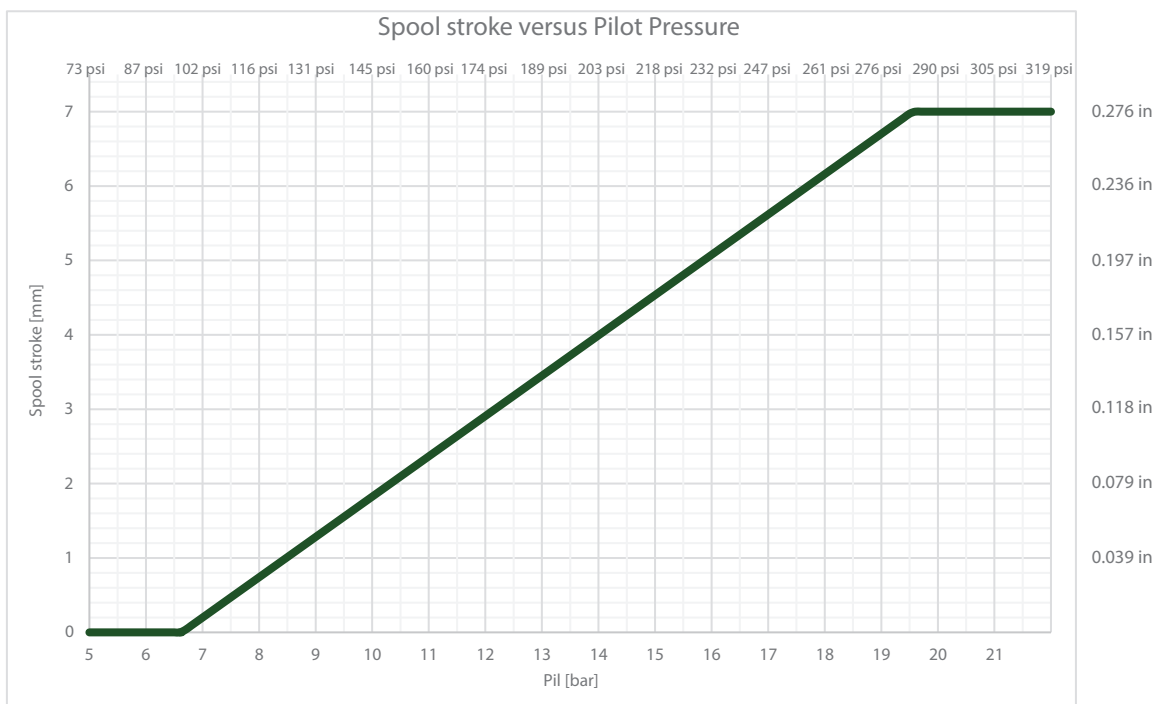

Figure 15-3: Proportional hydraulic control characteristic

The HP hydraulic control, being bilateral, does not require specifying the side for installation, so ordering it as HP is sufficient.

Request your Hydreco hydraulic joystick and specify pressure control curve 15, which is best suited for controlling directional valves of the MS family.

15.3 ELECTRO-HYDRAULIC PROPORTIONAL CONTROLS

15.3.1 PRELIMINARY NOTES

The electro-hydraulic controls must be powered via the pilot lines Pp and Tp, which are the supply and exhaust for the solenoid valves present in the controls.

Although Pp and Tp can be made available externally, it is common to use the pressure at the inlet of the directional valves, coming from the pump, to obtain the solenoid valve supply pressure via a pressure reducing valve (PRV) that flows into the pilot branch Pp. In this case, all Pp ports on the Inlet module should be plugged. Regarding the Tp exhaust, you can use the MD plug and one of the two connections on the Inlet module (recommended choice), or you can avoid using the MD plug and use the tank connected to the upper T port on the Outlet module.

If you supply the pilot pressure Pp externally, you will not need the PRV and the counter-pressure valve (CPV), so the PRV is replaced with a closure plug, and the CPV is simply not installed. Conversely, if you want to derive the pilot pressure internally, then both the PRV and the CPV are necessary because a minimum operating pressure must be made available at the distributor inlet to allow the PRV to provide a minimum pressure to actuate the spool in the section receiving the command.

In light of this, to use the electro-hydraulic controls, the Inlet modules for electro-hydraulic controls EH, the work sections for electro-hydraulic controls EH, and a compatible outlet module (95 if the CPV is necessary) are required.

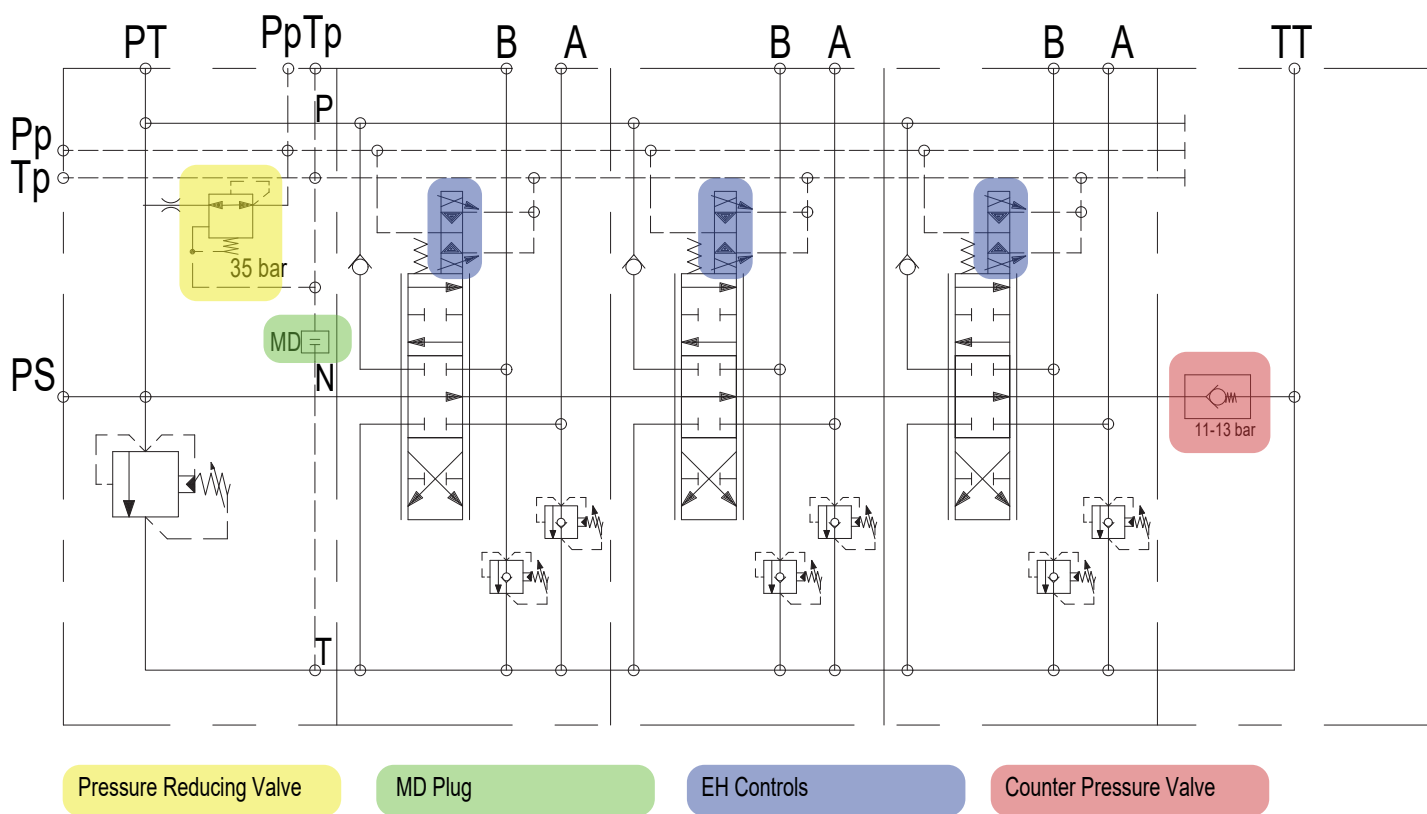

Figure 15-4: Typical hydraulic schematic for a directional valve with EH controls

When ordering a directional valve for electro-hydraulic controls, specify if you want the MD plug installed.

If you write MD after the section description in the "how to order" section, the plug will be installed, and you will use an external Tp connection. Specify MDO and the plug will not be installed, so you will not use an external Tp connection but the internal connection to the tank of the MS directional valve.

Note: the MD plug can be removed or installed later as well.

15.3.2 AVAILABLE ELECTRO-HYDRAULIC CONTROLS

15.3.2.1 SINGLE-SIDED ELECTRO-HYDRAULIC CONTROL EH

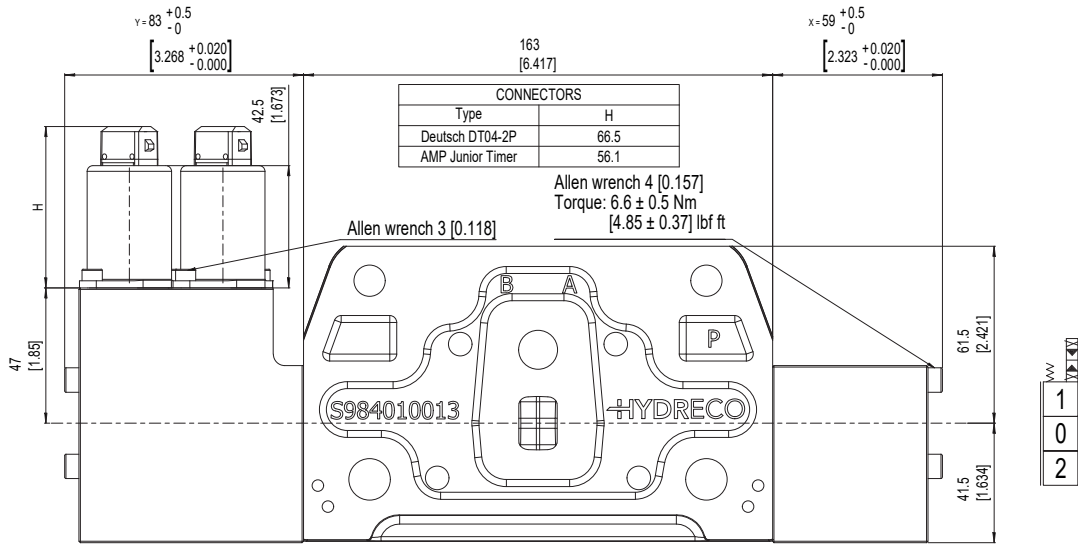

Figure 15-5: Single-sided electro-hydraulic control EH

The EH control is mounted by default on the B side, as shown in the figure, and is indicated as EHB in the how-to-order description or simply EH. However, it is also possible to order it on the other side by indicating EHA.

15.3.2.2 SINGLE-SIDED ELECTRO-HYDRAULIC CONTROL WITH LEVER EL

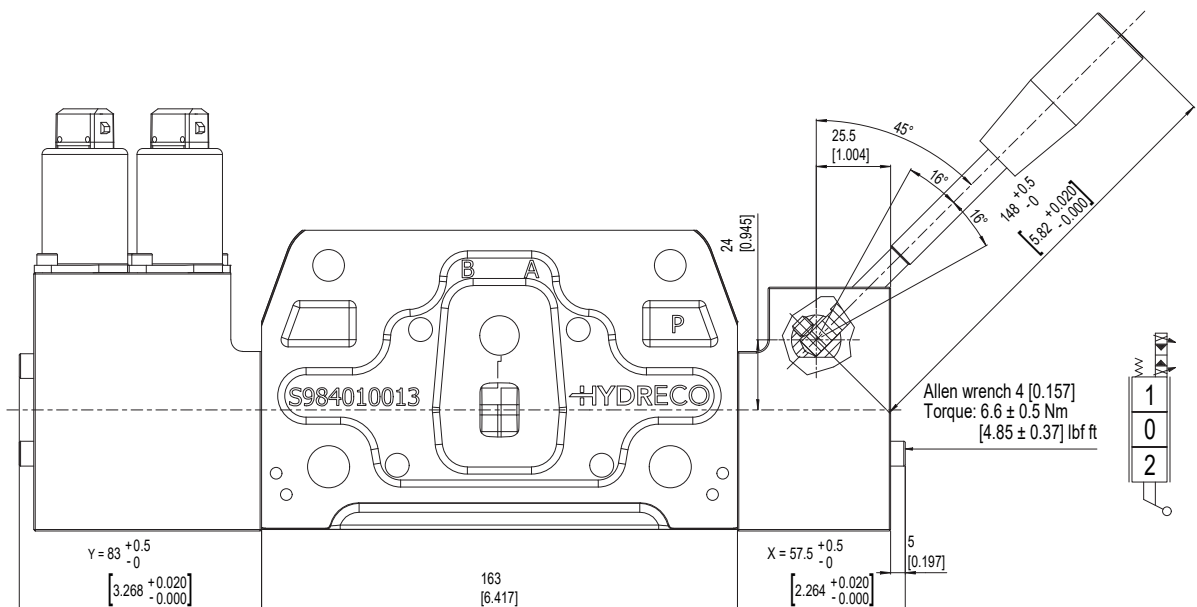

Figure 15-6: Single-sided electro-hydraulic control with lever EL

The EL control is mounted by default on the B side, as shown in the figure, and is indicated as ELB in the how-to-order description or simply EL. However, it is also possible to order it on the other side by indicating ELA.

15.3.3 PROPORTIONAL PRESSURE REDUCING VALVE DATA VALID FOR ALL VERSIONS

Electrical Data			
Voltage	12	24	VDC
Resolution	1500	750	mA
Resistance	4.72 ± 5%	20.8 ± 5%	Ω
Current in idle	24	20	mA
Type of Control	PWM 100 Hz Recommended		
Connectors			
Deutsch DT04-2P	√	√	H = 66.5 mm
AMP Junior Timer	√	√	H = 56.1 mm
Protection class	IP69		
Cable Length	500 mm		
Hydraulic Data			
Max. Pressure **: Pp max.	50	bar	
Hysteresis (w/PWM)	< 0.4		bar
Contamination Level	20/18/15	ISO 4406	
* for H dimension, see drawing			
** Maximum Pp value in case of external supply			

Table 15-1: Proportional pressure reducing valve data

15.3.4 PROPORTIONAL PRESSURE REDUCING VALVE DATA VALID FOR ALL VERSIONS

The proportional pressure reducing valve characteristic, intersected with the hydraulic control graph (Figure 15-3), yields the stroke vs. current graph for the 12V coil plotted in the Figure 15-7.

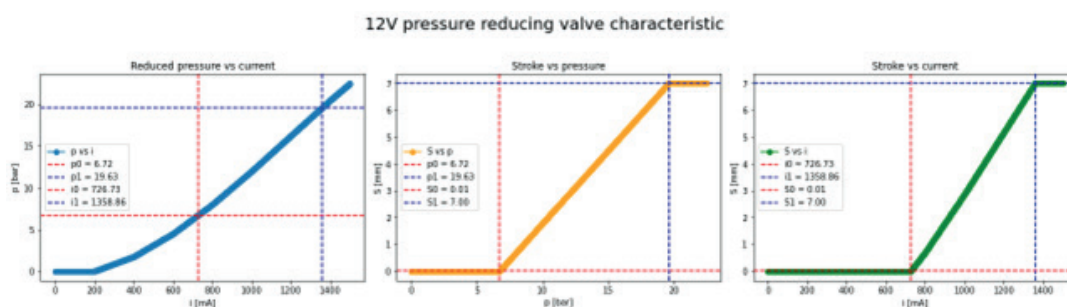

Figure 15-7: 12 V pressure reducing valve characteristic

The proportional pressure reducing valve characteristic, intersected with the hydraulic control graph (Figure 15-3), yields the stroke vs. current graph for the 24V coil plotted in the Figure 15-8.

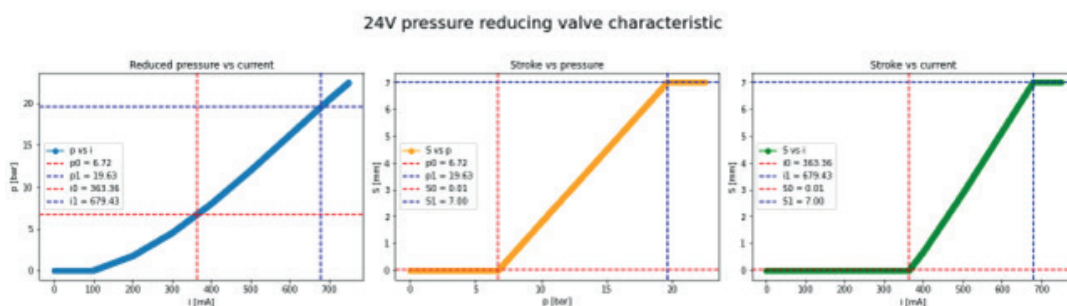

Figure 15-8: 24 V pressure reducing valve characteristic

15.3.4 SPOOL POSITIONINGS

15.4.1 SPRING-CENTERED TO NEUTRAL FOR 3-POSITION SPOOLS N3

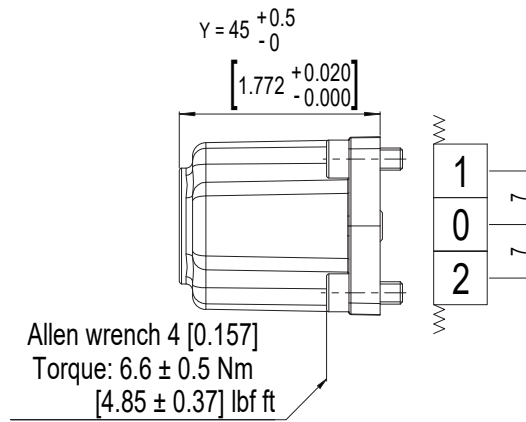

Figure 15-9: Spring-centered to neutral position for 3-position spools N3

Note: HP, EH, and EL controls already include the N3 positioner.

15.4.2 SPRING RETURN TO NEUTRAL FOR 4-POSITION SPOOLS WITH OR WITHOUT DETENT F1 AND F2

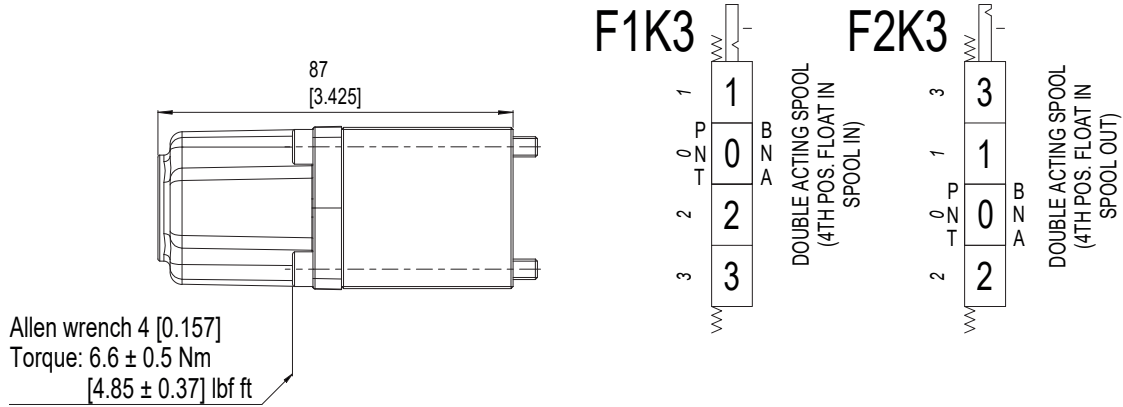
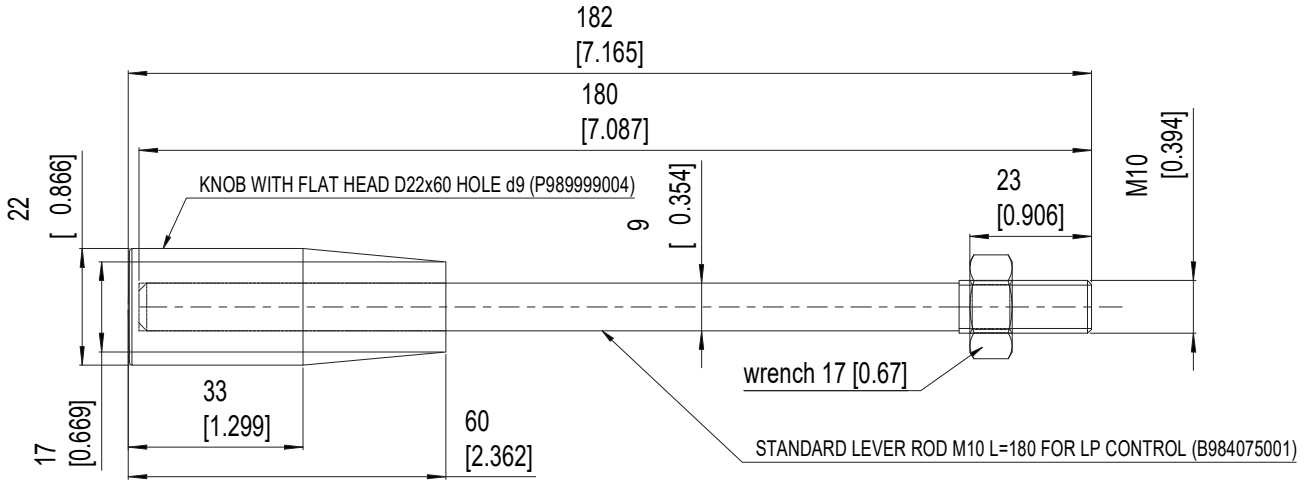

Figure 15-10: Detent on pos.3 with spring return in neutral F1 and F2

These positioners are used with the corresponding F1 and F2 spools. "K3" means that a detent is present in position 3.

16 STANDARD LEVER

STD



EL OPTION

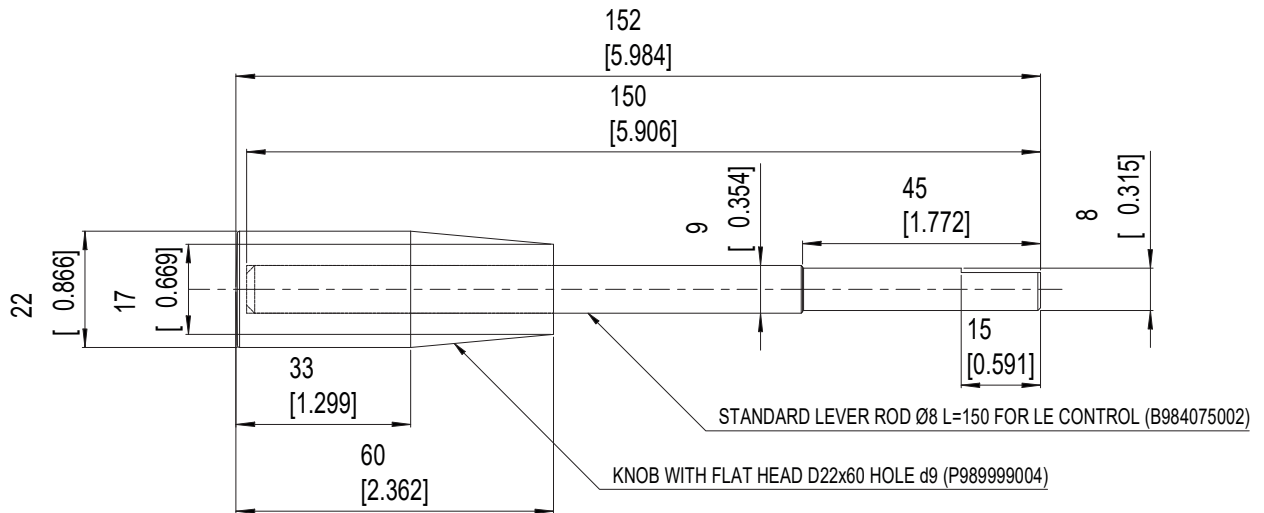

Figure 16-1: Standard lever

The levers shown in Figure 16 1, are not included in the how to order and must be requested specifically in a dedicated remarks area on the order form or communicated to the sales department. Additionally, any different requirements regarding length, diameter, and type of knob should be specified to the sales department to assess feasibility and sales conditions.

17 HOW TO ORDER



MODEL
MS100 Hydreco DCV

INLET MODULES
See Chapter 7

MAIN RELIEF VALVE
See Chapter 12
Column Setting Range

INLET OPTION
See Chapter 15.3.1

VENTING VALVE
SV0 No venting valve
SV1 12 V Open
SV2 12 V Close
SV3 24 V Open
SV4 24 V Close
See Chapter 13.4



NUMBER OF IDENTICAL CONSECUTIVE SECTIONS



WORKING SECTION
P Parallel

SPOOLS TYPE
See Chapter 11

FLOW
A Nominal
R 2/3 nom. flow

CONTROLS AND POSITIONERS
See Chapter 15

AUXILIARY VALVES
See Chapter 14.3



OUTLET MODULES
See Chapter 9

PORTS

- 1 ISO 1171-1 (GAS BSPP)
- 2 JIS B 2351-90 (GAS BSPP + O-Ring)
- 3 ISO 9974-1 (Metric ISO)
- 4 ISO 6149-1 (Metric ISO + O-Ring)
- 5 SAE ISO 11926-1 (SAE UNF + O-Ring)

See Chapter 6

Figure 17-1: How to order

17.1 ORDERING EXAMPLES

- MS 100 with side inlet and top outlet plugged (12) with a normally open 12V venting valve (SV1), main relief valve set at 350 bar, 4 sections connected in parallel, each with D1 spool, prepared for valves on the ports but plugged (AP), manual control MP on side A, and side T outlet with top outlet plugged (92).

MS 100 - 12 VS 350 - SV1 / 4 X P D1 - APA. APB - MPA - N3 / 92 - 1

- MS 100 with top and side inlet ports for EH control without venting valve (SV0), with MD plug separating the solenoid valves' exhaust from the distributor's T port (21), one section with electro-hydraulic control mounted on side B with lever and valves on ports AS set at 350 bar, one section with electro-hydraulic control mounted on side B without valves on ports (i.e., without cavities).
The spool in the first section is D2, and the spool in the second section is D1.

MS 100 - 21 VS 350 - SV0 - MD / P D2 - ASA350. ASB350 - ELB / P D1 - EHB / 95 - 1

Supported by a worldwide network



CONTACT INFORMATION

EMEA

GERMANY	Hydreco Hydraulics GmbH, Straelen (NRW)	☎ +49 283494303-41	✉ info-de@hydreco.com
ITALY	Hydreco Hydraulics Italia Srl, Vignola (MO)	☎ +39 059 7700411	✉ sales-it@hydreco.com
ITALY	Hydreco Hydraulics Italia Srl, Parma (PR)	☎ +39 0521 1830520	✉ sales-it@hydreco.com
ITALY	Hydreco Srl, San Cesario S/P (MO)	☎ +39 059 330091	✉ cylinders@hydreco.com
NORWAY	Hydreco Hydraulics Norway AS, Nittedal	☎ +47 22909410	✉ post-no@hydreco.com
UK	Hydreco Hydraulics Ltd, Poole, Dorset	☎ +44 (0) 1202 627500	✉ info-uk@hydreco.com

AMERICAS

NORTH/LATIN	Hydreco Inc / Continental Hydraulics Inc, Shakopee (MN)	☎ +1 952 895 6400	✉ sales@conthyd.com
--------------------	---	-------------------	---------------------

APAC

AUSTRALIA	Hydreco Hydraulics Pty Ltd, Seven Hills (NSW)	☎ +61 2 9838 6800	✉ sales-au@hydreco.com
AUSTRALIA	Hydreco Hydraulics Pty Ltd, Welshpool (WA)	☎ +61 8 9377 2211	✉ reception-wa@hydreco.com
INDIA	Hydreco Hydraulics India Private Ltd, Bangalore	☎ +91 80 67656300	✉ sales-in@hydreco.com

